



EXTRACTORDEAIRE.COM.MX

SQD/SQB

**Aero Ventiladores Cuadrados Centrífugos en Línea
ATC In Line Square Centrifugal Fans**

Indice

Características principales

Especificaciones técnicas SQD
Espectro de potencia sonora SQD

Curvas de operación SQD

Especificaciones técnicas SQB

Curvas de operación SQB

Espectro de potencia sonora SQB

Dimensiones generales

Table of Contents

Construction features

Performance data SQD
Sound pressure level ratings SQD

Operation curves SQD

Performance data SQB

Operation curves SQB

Sound pressure level ratings SQB

Dimensions



SQD/SQB

ATC Aero Ventiladores Cuadrados Centrífgos en Línea

La serie SQ de los Aero ventiladores cuadrados centrífugos en línea marca ATC con opción por transmisión de poleas y banda (SQB) y por transmisión directa (SQD), ha sido especialmente diseñada para montaje con ductos para los sistemas de inyección y extracción de aire en aplicaciones comerciales e industriales; disponibles en 9 tamaños con diámetros de turbina desde 10 1/4" hasta 24 5/8", ofreciendo la gama de ventiladores más versátil, silenciosa, eficiente y compacta manejando un rango amplio de caudal y presión en el mercado global.

Aplicaciones

Sistemas de ducto para aire acondicionado, ventilación y calefacción en oficinas, hospitales, estacionamientos públicos, centros comerciales e industrias en general.

Características principales

- Conjunto gabinete, paneles laterales, cono de succión, soporte del motor, chumaceras y perfiles estructurales fabricado en acero galvanizado de diferentes calibres altamente resistente a la corrosión.
- Turbina centrífuga de alta eficiencia y operación silenciosa con alabes rectos atrasados estática y dinámicamente balanceado, fabricada en aluminio en aleación y temple adecuado.
- Disponible en 2 diferentes posiciones de montaje (horizontal y vertical) con tacones antivibratorios o resortes colgantes y 2 diferentes rotaciones de rotor (CW-CCW).
- Chumaceras o rodamientos de alta eficiencia y mínimo mantenimiento diseñados para aplicaciones de servicio pesado adquiridos de los fabricantes mundialmente reconocidos.
- Flechas o ejes impulsores seleccionados en diferentes diámetros y longitudes según tamaño del ventilador, fabricados en acero AISI C-1045, perfectamente pulidos y rectificados en toda su longitud y protegidos con un recubrimiento anticorrosivo.
- Base ajustable de motor fabricada en acero al carbón y diseñada para ajuste, alineación y tensión de las bandas con una precisión y rapidez.
- Accionado por transmisión de poleas y bandas (SQB) y por transmisión directa (SQD) a los motores eléctricos de alta eficiencia diseñados bajo especificaciones NEMA, permitiendo lograr las distintas relaciones de caudal y presión.
- Construcción anti-chispa según clasificaciones de AMCA

Nomenclatura:

SQ B - 13 HP - CW

1 2 3 4 5

1. Modelo del ventilador
2. Tipo de transmisión: B-Poleas y banda D-Directo
3. Tamaño del ventilador
4. Construcción de la turbina:
HP: Turbina para alta presión / Sin HP: Turbina estándar.
5. Rotación de la turbina:
CW-Sentido del reloj / CCW-Sentido contra reloj

ATC In Line Square Centrifugal Fans

The SQ series are heavy duty square centrifugal fans constructed in direct and belt drive design with , reliable air movement in commercial and industrial applications. ATC duct mounted square in line centrifugal fans are available in 9 sizes with wheel diameters from 10 1 /4" through 24 5/8"; with different rotations and mounting positions, offering the line of most versatile, quite, energy efficient and compact fans which can handle a wide range of airflow and pressure in global market

Applications

HVAC systems, offices, hospitals, hotels, underground parking lots, commercial centers and industrial plants.

Construction features

- Housing, removable service panels, inlet cones, motor-drive stands and cover are made of bolted corrosion resistant galvanized steel construction.
- Backward inclined non-overloading wheels are constructed with aluminum, statically and dynamically balanced at the factory for most operating conditions.
- The fans are available in 2 different construction arrangements (horizontal and vertical) with floor mounted rubber isolators or ceiling mounted spring type isolators and 2 distinct wheel rotations; clockwise (CW) or counterclockwise (CCW).
- Self-aligning heavy duty, pillow block ball bearings are designed to operate under the most severe atmospheric conditions and are supplied by the most prestigious worldwide manufacturers.
- Shafts are designed for long life in different diameters and lengths, turned, ground and polished of solid SAE 1045 steel for smooth operation, key-wayed on each end and are protected with a corrosion resistant coating.
- Adjustable steel motor plate pivoted at one end for ease of belt tensioning.
- The SQ square inline centrifuga! series are the ideal choice for the general ventilation applications with the space saving advantages of an axial type fan in both belt drive (SQB) and direct drive (SQD) design.
- AMCA classifications for spark resistant construction where hazardous, explosive or flammable conditions exist.

Nomenclature:

SQ B - 13 HP - CW

1 2 3 4 5

1. Fan model
2. 1 Drive type: B-Belt drive. D-Direct drive
3. Fan size
4. Wheel construction
HP: High pressure wheel / Without HP: Standard wheel
5. Wheel rotation:
CW-Clockwise / CCW-Counterclockwise



SQD

Aero Ventiladores Cuadrados Centrífugos en Línea de Acoplamiento Directo
ATC Direct Drive In Line Square Centrifugal Fans

Especificaciones técnicas/Performance data

Modelo (Model)	Motor RPM	Motor HP	CFM vs Presión Estática (CFM vs Static Pressure)											
			0.000"	0.125"	0.250"	0.375"	0.500"	0.625"	0.750"	0.875"	1.000"	1.250"	1.500"	1.750"
SQD-07	1150	1/6	177	142	99	65								
	1725	1/3	269	208	154	103								
SQD-10	1150	1/6	684	587	476	378	298	236						
	1725	1/3	965	907	865	805	736	648	500					
SQD-12	1150	1/6	1176	1079	981	850								
	1725	1/2	1810	1745	1679	1616	1553	1484	1399	1302	1210			
SQD-13	1150	1/6	1554	1386	1250	1128	986							
	1725	3/4	2481	2404	2328	2254	2182	2112	2045	1980	1914	1765		
SQD-15	1150	1/2	2178	2038	1889	1734	1579	1417						
	1725	1	3479	3389	3297	3205	3111	3016	2922	2828	2737	2554	2361	
SQD-16	1150	1/2	2799	2665	2534	2407	2276	2131	1970	1774				
	1725	2	4473	4391	4311	4230	4150	4073	3995	3920	3843	3684	3508	3311

Los valores de caudal y presión están certificados para instalación tipo A: Succión y descarga libre sin ductos. Estos valores no incluyen los efectos de accesorios. Los valores de potencia (BHP) no incluyen las pérdidas por transmisión.

(Performance certified for installation type A: Free inlet and free outlet. Performance rating does not include the effects of accessories. Power rating (BHP) does not include transmission losses)

Espectro de potencia sonora/Sound Pressure Level Ratings

Model (Model)	RPM	Frecuencia / Frequency (Hz)									
		63	125	250	500	1K	2K	4K	8K	LWA	dB (A)
SQD-07	1150	47	53	52	46	39	35	30	23	47	35
	1725	57	63	61	59	48	45	43	36	58	46
SQD-10	1150	56	60	63	58	53	46	45	37	59	47
	1725	68	67	72	70	63	58	56	49	70	58
SQD-12	1150	63	68	70	64	58	60	48	43	65	53
	1725	70	79	80	79	72	69	66	57	80	68
SQD-13	1150	63	68	75	68	64	66	55	47	71	59
	1725	71	76	83	83	75	73	75	63	83	71
SQD-15	1150	69	73	78	74	66	65	57	52	76	64
	1725	75	83	86	87	82	75	73	66	88	76
SQD-16	1150	71	76	84	77	69	68	62	57	79	67
	1725	78	84	89	91	82	79	75	68	90	78

Datos obtenidos de acuerdo a la norma AMCA ESTANDAR 301. (Information obtained according to the AMCA STANDARD 301)

SQD

Curvas de operación/Performance Curves

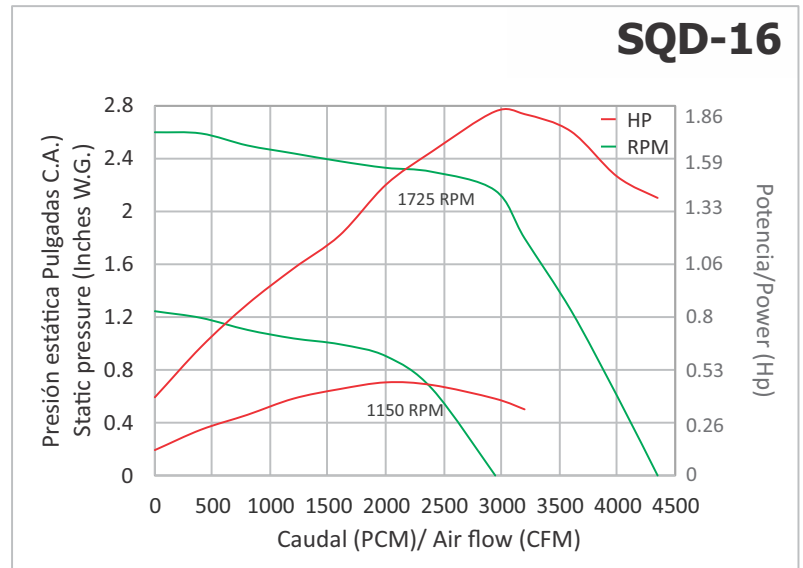
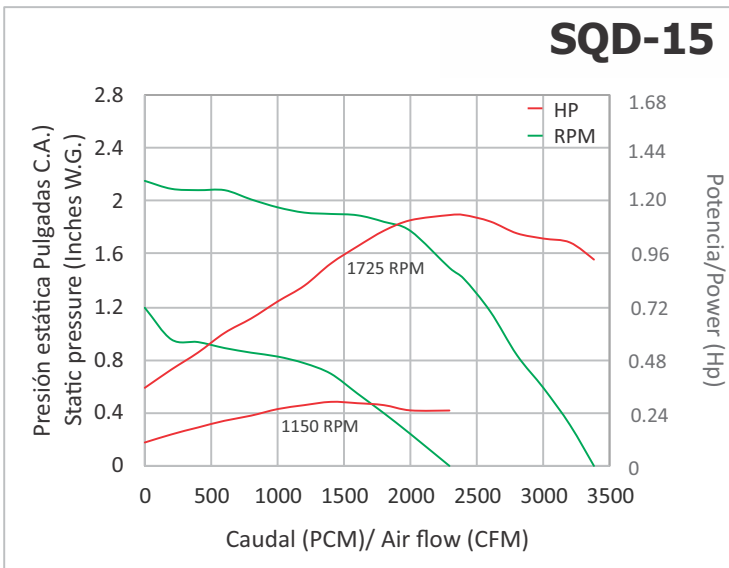
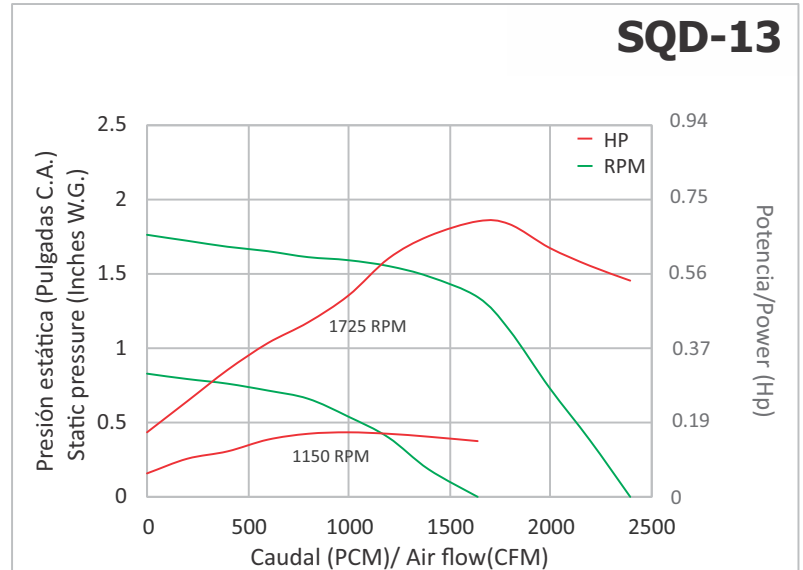
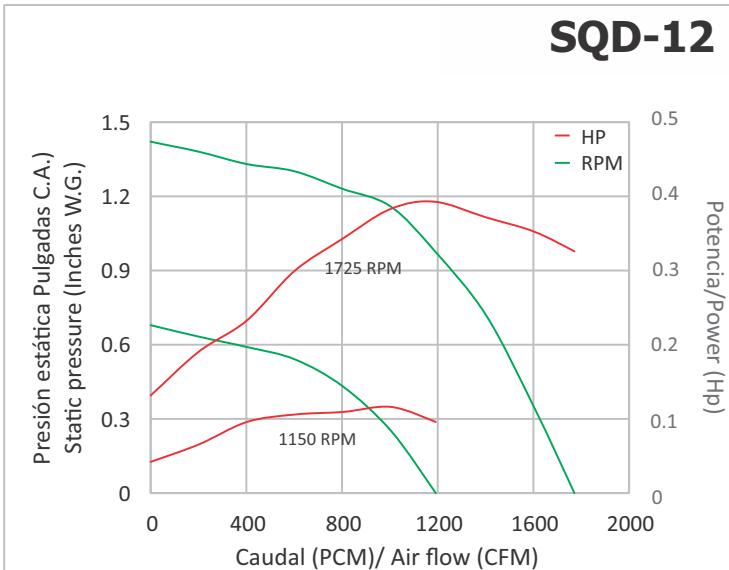
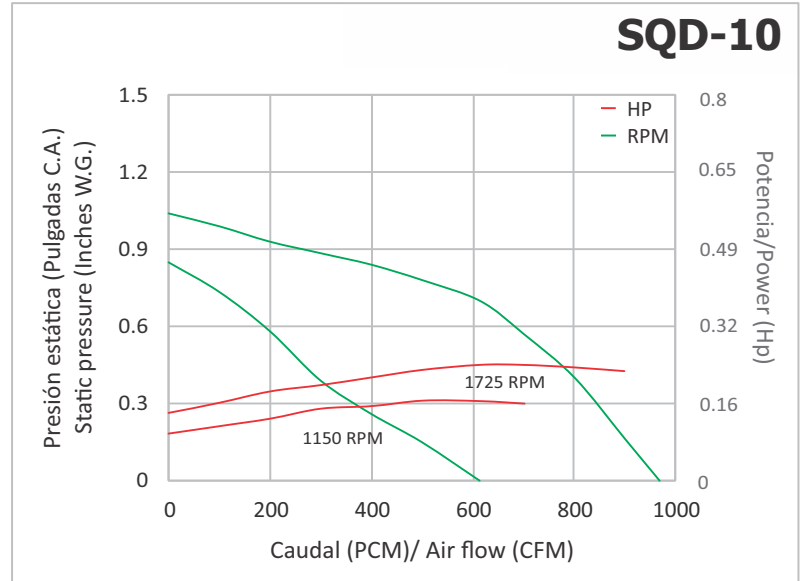
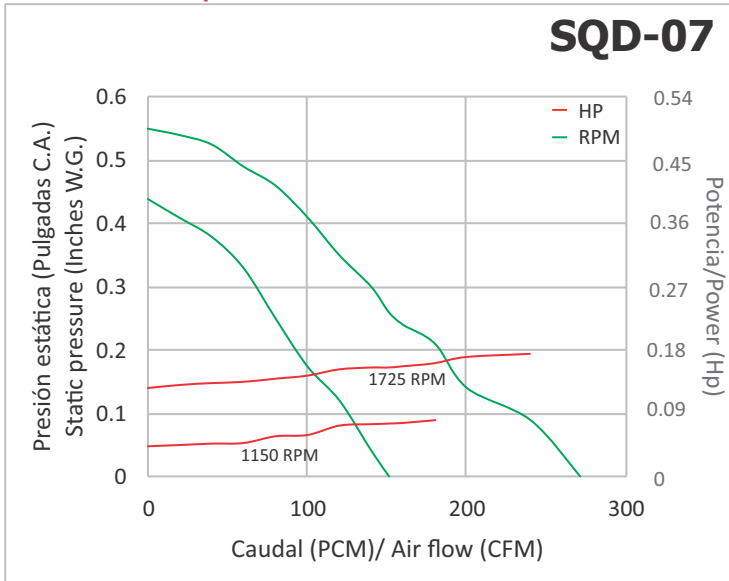

Todas las capacidades están basadas en la densidad estándar del aire de 0.075 lbs/ft³ @ 70°F y 0 pies de elevación: 1.2 kg/m³@21°C y 0 mt.
 (All capacities are based on the standard air density of 0.075 lbs/ft³ @ 70 °F and 0 ft Elevation: 1.2 kg/M³ @ 21 °c and 0 Mt.)



SQB

Aero Ventiladores Cuadrados Centrífugos en Línea con Transmisión por poleas y bandas / ATC Belt Drive In Line Square Centrifugal Fans

Especificaciones técnicas/Performance data

SQB-07

Diámetro de Turbina	10-1/4"	Wheel Diameter	10-1/4"
Diámetro de Flecha	1"	Shaft Diameter	1"
Área de Descarga	1.36 Ft ²	Outlet Area	1.36 Ft ²
RPM Max	3000	Max RPM	3000
Velocidad Tangencial (FPM)	2.68 X RPM	Tip Speed (FPM)	2.68 X RPM
BHP Max	0.0222 (RPM/1000) ³	Max. BHP	0.0222 (RPM/1000) ³
Armazón Max de Motor	145T	Max. Motor Frame Size	145T
Peso aproximado (Sin Motor)	52 Lb	Approx. Ship WT.(Less Motor)	52 Lb

Caudal (Volumen)		Velocidad Descarga (Outlet Velocity)	Presión Estática en Pulgadas C.A. (Static Pressure in Inches W. G.)																	
			0.125"		0.250"		0.500"		0.750"		1.000"		1.500"		2.000"		2.500"		3.000"	
CFM	M ³ /HR	FPM	RPM	BHP	RPM	BHP	RPM	BHP	RPM	BHP	RPM	BHP	RPM	BHP	RPM	BHP	RPM	BHP	RPM	BHP
145	246	107	986	0.02	1192	0.04	1503	0.08	1762	0.12	1994	0.18								
176	299	129	1099	0.03	1294	0.05	1594	0.09	1836	0.14	2050	0.19	2437	0.32						
207	352	152	1221	0.04	1402	0.06	1691	0.11	1924	0.16	2129	0.21	2492	0.34	2818	0.50				
238	404	175	1345	0.05	1513	0.08	1792	0.13	2020	0.18	2217	0.24	2563	0.37	2872	0.53	3157	0.70		
269	457	198	1471	0.07	1632	0.10	1898	0.15	2119	0.21	2311	0.27	2647	0.41	2942	0.57	3214	0.74	3468	0.93
300	510	221	1595	0.09	1753	0.12	2006	0.18	2222	0.24	2410	0.31	2737	0.46	3024	0.61	3285	0.79	3529	0.98
331	563	244	1721	0.11	1879	0.15	2118	0.21	2327	0.28	2512	0.35	2833	0.50	3112	0.67	3366	0.85	3601	1.04
362	615	266	1849	0.14	2003	0.18	2234	0.25	2435	0.32	2616	0.40	2931	0.56	3205	0.73	3453	0.91	3682	1.11
393	668	289	1977	0.17	2128	0.21	2354	0.29	2546	0.37	2721	0.45	3032	0.62	3302	0.80	3545	0.99	3768	1.19
424	721	312	2106	0.21	2253	0.25	2478	0.34	2661	0.42	2830	0.50	3135	0.68	3401	0.87	3640	1.07	3859	1.28
455	774	335	2238	0.25	2379	0.30	2602	0.39	2779	0.48	2941	0.56	3240	0.76	3502	0.95	3738	1.16	3954	1.37
486	826	358	2371	0.30	2505	0.35	2726	0.45	2900	0.54	3056	0.63	3347	0.83	3605	1.04	3837	1.25		
518	879	381	2503	0.35	2633	0.41	2851	0.51	3022	0.61	3174	0.71	3455	0.92	3710	1.13	3939	1.36		
549	932	403	2639	0.41	2761	0.47	2976	0.59	3146	0.69	3294	0.79	3566	1.01	3816	1.23				
580	985	426	2774	0.47	2891	0.54	3101	0.66	3271	0.78	3416	0.88	3679	1.11	3922	1.34				
611	1037	449	2907	0.55	3022	0.61	3226	0.75	3396	0.87	3539	0.98	3795	1.21						
642	1090	472	3045	0.63	3152	0.70	3351	0.84	3520	0.97	3662	1.09	3913	1.33						
673	1143	495	3183	0.72	3284	0.79	3477	0.93	3645	1.07	3787	1.21								
704	1196	518	3319	0.81	3417	0.89	3605	1.04	3770	1.19	3911	1.33								
735	1249	540	3455	0.92	3550	0.99	3732	1.15	3895	1.31										

Los valores de caudal y presión están certificados para instalación tipo A: Succión y descarga libre sin ductos. Estos valores no incluyen los efectos de accesorios. Los valores de potencia (BHP) no incluyen las pérdidas por transmisión. (Performance certified for installation type A: Free inlet and free outlet. Performance rating does not include the effects of accessories. Power rating (BHP) does not include transmission losses.)

SQB

Especificaciones técnicas/Performance data

SQB-10

Diámetro de Turbina	10 1/4"	Wheel Diameter	10 1/4"
Diámetro de Flecha	1"	Shaft Diameter	1"
Área de Descarga	1.36 Ft ²	Outlet Area	1.36 Ft ²
RPM Max	2800	Max RPM	2800
Velocidad Tangencial (PPM)	2.68 X RPM	Tip Speed (FPM)	2.68 X RPM
BHP Max	0.0351 (RPM/1000) ³	Max. BHP	0.0351 (RPM/1000) ³
Armazón Max de Motor	145T	Max. Motor Frame Size	145T
Peso aproximado (Sin Motor)	52 Lb	Approx. Ship WT.(Less Motor)	52 Lb

Caudal (Volumen)		Velocidad Descarga (Outlet Velocity)	Presión Estática en Pulgadas C.A. (Static Pressure in Inches W. G.)																	
			0.125"		0.250"		0.500"		0.750"		1.000"		1.500"		2.000"		2.500"		3.000"	
CFM	M ³ /HR	FPM	RPM	BHP	RPM	BHP	RPM	BHP	RPM	BHP	RPM	BHP	RPM	BHP	RPM	BHP	RPM	BHP	RPM	BHP
731	1242	538	1440	0.10	1544	0.13	1741	0.19	1919	0.25	2087	0.32								
775	1317	570	1514	0.12	1614	0.15	1801	0.20	1975	0.27	2133	0.34								
820	1393	603	1589	0.14	1685	0.17	1862	0.23	2032	0.29	2184	0.37								
865	1470	636	1663	0.16	1756	0.19	1925	0.25	2090	0.32	2238	0.39								
910	1546	669	1739	0.18	1829	0.21	1990	0.28	2148	0.35	2295	0.42	2567	0.59						
955	1623	702	1814	0.21	1902	0.24	2057	0.31	2208	0.38	2352	0.46	2613	0.63						
1000	1699	735	1889	0.24	1976	0.27	2125	0.34	2269	0.41	2410	0.49	2664	0.66						
1045	1775	768	1966	0.27	2048	0.30	2195	0.37	2332	0.45	2469	0.53	2718	0.70	2958	0.91				
1090	1852	801	2043	0.30	2123	0.34	2265	0.41	2396	0.48	2528	0.57	2774	0.75	3004	0.95				
1135	1928	835	2120	0.33	2198	0.37	2334	0.45	2462	0.52	2589	0.61	2831	0.80	3054	1.00				
1180	2005	868	2196	0.37	2271	0.41	2406	0.49	2529	0.57	2651	0.65	2888	0.85	3106	1.05				
1225	2081	901	2272	0.41	2346	0.45	2477	0.53	2597	0.61	2713	0.70	2946	0.90	3161	1.11				
1270	2158	934	2349	0.45	2422	0.50	2550	0.58	2666	0.66	2778	0.75	3005	0.95						
1315	2234	967	2428	0.50	2498	0.55	2622	0.63	2736	0.72	2844	0.81	3064	1.01						
1360	2311	1000	2507	0.55	2572	0.60	2696	0.69	2806	0.78	2911	0.87	3124	1.07						
1405	2387	1033	2585	0.61	2646	0.65	2770	0.75	2876	0.84	2979	0.93	3185	1.13						
1450	2464	1066	2664	0.66	2722	0.71	2843	0.81	2948	0.90	3047	0.99								
1495	2540	1099	2742	0.72	2800	0.77	2915	0.87	3020	0.97	3117	1.06								
1540	2616	1132	2820	0.79	2877	0.84	2989	0.94	3092	1.04	3187	1.14								
1585	2693	1165	2898	0.85	2954	0.90	3064	1.01	3165	1.11										

SQB-12

Diámetro de Turbina	12 1/2"	Wheel Diameter	12 1/2"
Diámetro de Flecha	1"	Shaft Diameter	1"
Área de Descarga	1.78 Ft ²	Outlet Area	1.78 Ft ²
RPM Max	2600	Max RPM	2600
Velocidad Tangencial (PPM)	3.27 X RPM	Tip Speed (FPM)	3.27 X RPM
BHP Max	0.0815 (RPM/1000) ³	Max. BHP	0.0815 (RPM/1000) ³
Armazón Max de Motor	145T	Max. Motor Frame Size	145T
Peso aproximado (Sin Motor)	56 Lb	Approx. Ship WT.(Less Motor)	56 Lb

Caudal (Volumen)		Velocidad Descarga (Outlet Velocity)	Presión Estática en Pulgadas C.A. (Static Pressure in Inches W. G.)																	
			0.125"		0.250"		0.500"		0.750"		1.000"		1.500"		2.000"		2.500"		3.000"	
CFM	M ³ /HR	FPM	RPM	BHP	RPM	BHP	RPM	BHP	RPM	BHP	RPM	BHP	RPM	BHP	RPM	BHP	RPM	BHP	RPM	BHP
927	1575	521	1025	0.09	1120	0.11	1255	0.16	1392	0.22										
1010	1716	568	1099	0.11	1190	0.14	1324	0.19	1443	0.24	1577	0.32								
1093	1857	614	1175	0.13	1260	0.16	1395	0.22	1503	0.28	1618	0.35								
1176	1998	661	1250	0.16	1331	0.19	1466	0.26	1570	0.32	1672	0.38								
1259	2139	707	1328	0.19	1403	0.22	1538	0.30	1640	0.36	1732	0.42	1940	0.60						
1342	2280	754	1405	0.23	1476	0.26	1609	0.34	1711	0.41	1799	0.47	1984	0.64						
1425	2421	801	1484	0.27	1550	0.30	1678	0.39	1783	0.46	1868	0.53	2036	0.69	2226	0.90				
1508	2562	847	1563	0.31	1625	0.35	1748	0.44	1854	0.52	1938	0.59	2096	0.75	2266	0.95				
1591	2703	894	1642	0.36	1701	0.40	1819	0.49	1925	0.58	2010	0.66	2160	0.82	2314	1.01	2485	1.25		
1674	2844	940	1720	0.41	1777	0.46	1890	0.55	1996	0.65	2081	0.73	2227	0.90	2369	1.08	2524	1.31		
1757	2985	987	1800	0.48	1854	0.52	1961	0.61	2065	0.72	2153	0.81	2297	0.99	2429	1.17	2571	1.39		
1840	3126	1034	1882	0.54	1931	0.59	2033	0.68	2135	0.79	2224	0.90	2367	1.08	2494	1.27	2624	1.47		
1923	3267	1080	1963	0.62	2007	0.66	2107	0.76	2205	0.87	2294	0.98	2437	1.18	2561	1.37				
2006	3408	1127	2043	0.69	2087	0.74	2180	0.84	2275	0.96	2364	1.08	2510	1.29	2630	1.48				
2089	3549	1173	2124	0.78	2166	0.83	2255	0.94	2346	1.05	2434	1.18	2581	1.40	2700	1.60				
2172	3690	1220	2204	0.87	2245	0.92	2331	1.03	2418	1.15	2504	1.28	2652	1.52						
2255	3830	1267	2283	0.97	2324	1.02	2406	1.14	2490	1.26	2574	1.39	2723	1.65						
2338	3971	1313	2362	1.07	2402	1.13	2481	1.24	2564	1.37	2644	1.51								
2420	4112	1360	2441	1.19	2481	1.24	2560	1.37	2637	1.50	2715	1.63								
2503	4253	1406	2524	1.31	2562	1.37	2637	1.49	2710	1.62	2787	1.76								

Los valores de caudal y presión están certificados para instalación tipo A: Succión y descarga libre sin ductos. Estos valores no incluyen los efectos de accesorios. Los valores de potencia (BHP) no incluyen las pérdidas por transmisión. (Performance certified for installation type A: Free inlet and free outlet. Performance rating does not include the effects of accessories. Power rating (BHP) does not include transmission losses.)

SQB

Especificaciones técnicas/Performance data

SQB-13

Diámetro de Turbina	14"	Wheel Diameter	14"
Diámetro de Flecha	1"	Shaft Diameter	1"
Area de Descarga	2.25 Ft ²	Outlet Area	2.25 Ft ²
RPM Max	2300	Max RPM	2300
Velocidad Tangencial (FPM)	3.67 X RPM	Tip Speed (FPM)	3.67 X RPM
BHP Max	0.1411 (RPM/1000) ³	Max. BHP	0.1411 (RPM/1000) ³
Armazón Max de Motor	145	Max. Motor Frame Size	145
Peso aproximado (Sin Motor)	59 Lb	Approx. Ship WT.(Less Motor)	59 Lb

Caudal (Volumen)		Velocidad Descarga (Outlet Velocity)	Presión Estática en Pulgadas C.A. (Static Pressure in Inches W. G.)																	
			0.125"		0.250"		0.500"		0.750"		1.000"		1.500"		2.000"		2.500"		3.000"	
CFM	M ³ /HR	FPM	RPM	BHP	RPM	BHP	RPM	BHP	RPM	BHP	RPM	BHP	RPM	BHP	RPM	BHP	RPM	BHP	RPM	BHP
1298	2205	577	1030	0.15	1106	0.19	1240	0.27	1354	0.35	1464	0.44								
1384	2352	615	1087	0.18	1161	0.22	1289	0.30	1403	0.39	1502	0.48								
1471	2499	654	1147	0.21	1216	0.25	1339	0.34	1451	0.43	1548	0.52								
1557	2646	692	1206	0.25	1273	0.29	1391	0.38	1500	0.48	1596	0.57								
1644	2793	731	1266	0.29	1330	0.33	1443	0.42	1549	0.52	1645	0.63	1816	0.84						
1730	2940	769	1326	0.33	1387	0.38	1496	0.47	1599	0.58	1694	0.69	1858	0.90						
1817	3087	807	1385	0.38	1445	0.43	1550	0.53	1650	0.63	1743	0.75	1904	0.97						
1903	3234	846	1447	0.43	1503	0.48	1605	0.58	1701	0.69	1792	0.81	1952	1.05	2099	1.30				
1990	3381	884	1508	0.48	1562	0.54	1661	0.65	1754	0.76	1842	0.88	2000	1.13	2141	1.39	2270	1.65		
2076	3528	923	1569	0.54	1621	0.60	1716	0.71	1806	0.83	1893	0.96	2049	1.21	2187	1.48	2323	1.77		
2163	3675	961	1629	0.61	1680	0.67	1773	0.79	1860	0.91	1943	1.04	2099	1.30	2234	1.57	2368	1.87		
2249	3822	1000	1689	0.68	1739	0.74	1829	0.86	1915	0.99	1995	1.12	2148	1.40	2283	1.68				
2336	3969	1038	1751	0.76	1801	0.82	1887	0.95	1969	1.08	2048	1.21	2197	1.50	2332	1.79				
2422	4116	1077	1813	0.84	1861	0.91	1944	1.04	2025	1.17	2101	1.31	2247	1.60						
2509	4263	1115	1875	0.93	1920	1.00	2002	1.13	2080	1.27	2155	1.41	2298	1.71						
2595	4410	1154	1937	1.03	1979	1.09	2060	1.23	2137	1.38	2209	1.52	2347	1.83						
2682	4557	1192	1999	1.13	2041	1.20	2118	1.34	2193	1.49	2264	1.64								
2768	4704	1230	2061	1.24	2102	1.31	2177	1.45	2249	1.61	2319	1.76								
2855	4851	1269	2123	1.35	2163	1.43	2237	1.58	2307	1.73	2375	1.89								
2941	4998	1307	2185	1.47	2224	1.55	2296	1.71	2365	1.87										

SQB-13 HP

Diámetro de Turbina	14"	Wheel Diameter	14"
Diámetro de Flecha	1"	Shaft Diameter	1"
Area de Descarga	2.25 Ft ²	Outlet Area	2.25 Ft ²
RPM Max	2500	Max RPM	2500
Velocidad Tangencial (FPM)	3.67 X RPM	Tip Speed (FPM)	3.67 X RPM
BHP Max	0.1007 (RPM/1000) ³	Max. BHP	0.1007 (RPM/1000) ³
Armazón Max de Motor	145T	Max. Motor Frame Size	145T
Peso aproximado (Sin Motor)	59 Lb	Approx. Ship WT.(Less Motor)	59 Lb

Caudal (Volumen)		Velocidad Descarga (Outlet Velocity)	Presión Estática en Pulgadas C.A. (Static Pressure in Inches W. G.)																	
			0.250"		0.500"		1.000"		1.500"		2.000"		2.500"		3.000"		4.000"		5.000"	
CFM	M ³ /HR	FPM	RPM	BHP	RPM	BHP	RPM	BHP	RPM	BHP	RPM	BHP	RPM	BHP	RPM	BHP	RPM	BHP	RPM	BHP
969	1646	431	995	0.10	1158	0.16	1440	0.30	1704	0.50	1947	0.74								
1042	1770	463	1045	0.12	1199	0.17	1470	0.32	1717	0.51	1955	0.75								
1114	1893	495	1098	0.13	1242	0.19	1503	0.34	1738	0.53	1965	0.76	2178	1.04						
1187	2017	528	1151	0.15	1287	0.21	1538	0.37	1764	0.55	1977	0.78	2186	1.05	2380	1.36				
1260	2140	560	1205	0.18	1334	0.24	1575	0.39	1794	0.58	1995	0.80	2196	1.07	2388	1.37				
1332	2264	592	1261	0.20	1382	0.27	1613	0.42	1827	0.61	2020	0.83	2209	1.09	2396	1.39				
1405	2387	624	1316	0.23	1433	0.30	1652	0.45	1861	0.65	2048	0.86	2227	1.11	2407	1.40				
1478	2511	657	1373	0.26	1483	0.33	1693	0.49	1897	0.69	2078	0.90	2251	1.15	2421	1.43				
1550	2634	689	1429	0.29	1535	0.36	1736	0.53	1933	0.73	2112	0.95	2278	1.19	2441	1.46				
1623	2758	721	1487	0.33	1588	0.40	1779	0.57	1971	0.77	2147	1.00	2309	1.24	2465	1.51				
1696	2881	754	1545	0.37	1642	0.45	1825	0.61	2010	0.82	2182	1.05	2341	1.29	2493	1.56				
1768	3005	786	1603	0.42	1697	0.49	1872	0.66	2051	0.87	2218	1.10	2375	1.35	2522	1.62				
1841	3128	818	1662	0.46	1752	0.54	1920	0.71	2093	0.92	2256	1.16	2409	1.41						
1914	3252	851	1720	0.51	1807	0.59	1970	0.77	2135	0.98	2294	1.22	2445	1.47						
1986	3375	883	1779	0.57	1863	0.65	2019	0.83	2180	1.04	2334	1.28	2482	1.54						
2059	3498	915	1837	0.62	1920	0.71	2069	0.89	2225	1.11	2374	1.35	2519	1.61						
2132	3622	947	1898	0.69	1977	0.78	2121	0.96	2272	1.18	2417	1.42								
2204	3745	980	1958	0.76	2033	0.85	2173	1.03	2319	1.26	2459	1.50								
2277	3869	1012	2017	0.83	2092	0.92	2226	1.11	2367	1.34	2503	1.58								
2350	3992	1044	2077	0.90	2149	1.00	2279	1.19	2416	1.42										

Los valores de caudal y presión están certificados para instalación tipo A: Succión y descarga libre sin ductos. Estos valores no incluyen los efectos de accesorios. Los valores de potencia (BHP) no incluyen las pérdidas por transmisión. (Performance certified for installation type A: Free inlet and free outlet. Performance rating does not include the effects of accessories. Power rating (BHP) does not include transmission losses.)

SQB

Especificaciones técnicas/Performance data

SQB-15

Diámetro de Turbina	15 1/8"	Wheel Diameter	15 1/8"
Diámetro de Flecha	1 1/8"	Shaft Diameter	1 1/8"
Area de Descarga	2.78 Ft ²	Outlet Area	2.78 Ft ²
RPM Max	2100	Max RPM	2100
Velocidad Tangencial (FPM)	3.96 X RPM	Tip Speed (FPM)	3.96 X RPM
BHP Max	0.2503 (RPM/1000) ³	Max. BHP	0.2503 (RPM/1000) ³
Armazón Max de Motor	145T	Max. Motor Frame Size	145T
Peso aproximado (Sin Motor)	68 Lb	Approx. Ship WT.(Less Motor)	68 Lb

Caudal (Volumen)		Velocidad Descarga (Outlet Velocity)	Presión Estática en Pulgadas C.A. (Static Pressure in Inches W. G.)																	
			0.125"		0.250"		0.500"		0.750"		1.000"		1.500"		2.000"		2.500"		3.000"	
CFM	M ³ /HR	FPM	RPM	BHP	RPM	BHP	RPM	BHP	RPM	BHP	RPM	BHP	RPM	BHP	RPM	BHP	RPM	BHP	RPM	BHP
1729	2937	622	860	0.16	937	0.21	1078	0.31	1208	0.44	1336	0.60								
1862	3164	670	915	0.19	986	0.24	1120	0.35	1244	0.48	1362	0.63								
1996	3392	718	970	0.23	1036	0.28	1166	0.40	1281	0.53	1394	0.68								
2130	3619	766	1026	0.27	1089	0.32	1211	0.44	1323	0.58	1429	0.73	1637	1.10						
2264	3846	814	1083	0.32	1141	0.37	1258	0.50	1366	0.64	1467	0.79	1663	1.15						
2398	4073	862	1140	0.37	1195	0.43	1306	0.56	1410	0.70	1507	0.86	1694	1.22						
2531	4301	911	1198	0.43	1249	0.49	1355	0.62	1455	0.77	1549	0.93	1727	1.29	1902	1.72				
2665	4528	959	1255	0.49	1304	0.55	1405	0.69	1502	0.85	1592	1.01	1763	1.37	1929	1.80	2064	2.20		
2799	4755	1007	1313	0.57	1359	0.63	1455	0.77	1549	0.93	1637	1.10	1802	1.47	1961	1.89	2119	2.38		
2933	4983	1055	1372	0.65	1415	0.71	1507	0.86	1596	1.02	1682	1.19	1842	1.56	1995	1.99	2145	2.47		
3066	5210	1103	1430	0.73	1471	0.80	1559	0.95	1646	1.12	1728	1.29	1884	1.67	2032	2.10	2184	2.61		
3200	5437	1151	1487	0.82	1528	0.89	1611	1.05	1695	1.22	1775	1.40	1927	1.79	2070	2.22	2225	2.76		
3334	5664	1199	1546	0.92	1584	1.00	1665	1.15	1745	1.33	1823	1.52	1971	1.92	2109	2.35				
3468	5892	1247	1606	1.04	1643	1.11	1719	1.27	1796	1.45	1872	1.64	2016	2.05						
3602	6119	1296	1666	1.16	1699	1.23	1773	1.39	1848	1.58	1921	1.77	2061	2.19						
3735	6346	1344	1724	1.28	1756	1.35	1828	1.53	1899	1.71	1970	1.91	2107	2.34						
3869	6573	1392	1784	1.42	1814	1.50	1884	1.67	1952	1.86	2020	2.06								
4003	6801	1440	1844	1.57	1873	1.64	1938	1.82	2005	2.02	2072	2.23								
4137	7028	1488	1902	1.72	1932	1.80	1994	1.99	2058	2.18	2123	2.39								
4270	7255	1536	1961	1.89	1989	1.97	2051	2.16	2113	2.36										

SQB-15 HP

Diámetro de Turbina	15 1/8"	Wheel Diameter	15 1/8"
Diámetro de Flecha	1 1/8"	Shaft Diameter	1 1/8"
Area de Descarga	2.78 Ft ²	Outlet Area	2.78 Ft ²
RPM Max	2700	Max RPM	2700
Velocidad Tangencial (FPM)	3.96 X RPM	Tip Speed (FPM)	3.96 X RPM
BHP Max	0.1125 (RPM/1000) ³	Max. BHP	0.1125 (RPM/1000) ³
Armazón Max de Motor	145T	Max. Motor Frame Size	145T
Peso aproximado (Sin Motor)	68 Lb	Approx. Ship WT.(Less Motor)	68 Lb

Caudal (Volumen)		Velocidad Descarga (Outlet Velocity)	Presión Estática en Pulgadas C.A. (Static Pressure in Inches W. G.)																	
			0.250"		0.500"		1.000"		1.500"		2.000"		2.500"		3.000"		4.000"		5.000"	
CFM	M ³ /HR	FPM	RPM	BHP	RPM	BHP	RPM	BHP	RPM	BHP	RPM	BHP	RPM	BHP	RPM	BHP	RPM	BHP	RPM	BHP
584	992	210	795	0.06	982	0.11	1285	0.24	1541	0.41										
681	1157	245	861	0.07	1034	0.12	1319	0.26	1563	0.43	1778	0.63								
778	1323	280	930	0.09	1095	0.15	1363	0.29	1593	0.46	1801	0.66	1990	0.89	2162	1.14				
876	1488	315	1005	0.11	1160	0.18	1412	0.32	1632	0.49	1830	0.69	2013	0.92	2183	1.17	2489	1.73		
973	1653	350	1084	0.14	1226	0.21	1465	0.35	1677	0.53	1865	0.73	2041	0.96	2207	1.21	2509	1.78	2778	2.41
1070	1818	385	1168	0.18	1294	0.24	1526	0.40	1726	0.58	1909	0.78	2077	1.01	2235	1.26	2531	1.83	2799	2.47
1168	1984	420	1252	0.22	1367	0.29	1590	0.45	1779	0.63	1956	0.84	2118	1.07	2271	1.32	2557	1.88	2821	2.52
1265	2149	455	1338	0.27	1444	0.34	1655	0.51	1838	0.70	2006	0.91	2165	1.14	2312	1.39	2588	1.95	2855	2.62
1362	2314	490	1424	0.32	1524	0.40	1721	0.57	1900	0.77	2060	0.98	2213	1.22	2357	1.47	2625	2.03	2888	2.71
1460	2480	525	1511	0.39	1607	0.47	1789	0.64	1965	0.85	2120	1.07	2265	1.31	2405	1.56	2666	2.13		
1557	2645	560	1599	0.46	1691	0.54	1859	0.72	2030	0.94	2182	1.17	2321	1.41	2456	1.67	2712	2.24		
1654	2810	595	1687	0.54	1775	0.63	1932	0.81	2096	1.04	2245	1.27	2381	1.52	2510	1.78				
1751	2976	630	1776	0.63	1860	0.72	2008	0.91	2163	1.14	2311	1.39	2443	1.64	2568	1.90				
1849	3141	665	1864	0.73	1947	0.83	2087	1.02	2232	1.25	2376	1.51	2508	1.77	2629	2.04				
1946	3306	700	1953	0.84	2033	0.95	2168	1.15	2304	1.38	2443	1.64	2572	1.92	2692	2.20				
2043	3472	735	2044	0.96	2120	1.07	2250	1.28	2377	1.51	2509	1.78	2638	2.07						
2141	3637	770	2134	1.09	2208	1.21	2333	1.43	2453	1.66	2579	1.93	2704	2.22						
2238	3802	805	2223	1.24	2295	1.36	2418	1.59	2531	1.82	2651	2.09								
2335	3968	840	2312	1.39	2384	1.52	2502	1.76	2612	2.00	2723	2.27								
2433	4133	875	2404	1.56	2473	1.70	2587	1.95	2694	2.20										

Los valores de caudal y presión están certificados para instalación tipo A: Succión y descarga libre sin ductos. Estos valores no incluyen los efectos de accesorios. Los valores de potencia (BHP) no incluyen las pérdidas por transmisión. (Performance certified for installation type A: Free inlet and free outlet. Performance rating does not include the effects of accessories. Power rating (BHP) does not include transmission losses.)

SQB

Especificaciones técnicas/Performance data

SQB-16

Diámetro de Turbina	16-11/16"	Wheel Diameter	16-11/16"
Diámetro de Flecha	1 1/8"	Shaft Diameter	1 1/8"
Area de Descarga	3.67 Ft ²	Outlet Area	3.67 Ft ²
RPM Max	2100	Max RPM	2100
Velocidad Tangencial (FPM)	4.37 X RPM	Tip Speed (FPM)	4.37 X RPM
BHP Max	0.4012 (RPM/1000) ³	Max. BHP	0.4012 (RPM/1000) ³
Armazón Max de Motor	184T	Max. Motor Frame Size	184T
Peso aproximado (Sin Motor)	81 Lb	Approx. Ship WT.(Less Motor)	81 Lb

Caudal (Volumen)		Velocidad Descarga (Outlet Velocity)	Presión Estática en Pulgadas C.A. (Static Pressure in Inches W. G.)																		
			0.125"		0.250"		0.500"		0.750"		1.000"		1.500"		2.000"		2.500"		3.000"		
CFM	M ³ /HR	FPM	RPM	BHP	RPM	BHP	RPM	BHP	RPM	BHP	RPM	BHP	RPM	BHP	RPM	BHP	RPM	BHP	RPM	BHP	
1813	3080	494	728	0.15	803	0.21	917	0.31	1050	0.46	1185	0.67									
2020	3432	550	796	0.20	863	0.26	974	0.37	1078	0.50	1203	0.70									
2227	3784	607	865	0.26	924	0.32	1035	0.44	1124	0.57	1228	0.74	1450	1.22							
2435	4136	663	936	0.33	988	0.39	1097	0.53	1180	0.66	1265	0.81	1467	1.27							
2642	4488	720	1008	0.41	1054	0.47	1157	0.62	1241	0.77	1314	0.91	1490	1.33	1678	1.89					
2849	4840	776	1081	0.51	1122	0.57	1217	0.72	1303	0.89	1373	1.04	1521	1.41	1697	1.96	1865	2.60			
3056	5192	833	1152	0.61	1191	0.68	1278	0.84	1364	1.02	1434	1.18	1564	1.54	1720	2.04	1882	2.68			
3263	5545	889	1225	0.74	1262	0.81	1340	0.96	1424	1.16	1496	1.34	1616	1.69	1750	2.15	1903	2.77	2053	3.47	
3471	5897	946	1300	0.88	1332	0.95	1404	1.11	1484	1.31	1556	1.51	1674	1.88	1791	2.30	1928	2.87	2073	3.57	
3678	6249	1002	1373	1.04	1404	1.11	1471	1.28	1543	1.48	1616	1.69	1735	2.09	1840	2.50	1961	3.02	2094	3.68	
3885	6601	1059	1447	1.21	1476	1.29	1538	1.46	1605	1.66	1676	1.89	1797	2.33	1897	2.74	2001	3.21			
4092	6953	1115	1520	1.41	1548	1.49	1607	1.66	1669	1.87	1736	2.10	1858	2.57	1955	3.00	2050	3.46			
4299	7305	1171	1592	1.62	1620	1.70	1675	1.89	1733	2.09	1796	2.33	1919	2.84	2017	3.29					
4507	7657	1228	1667	1.86	1692	1.94	1746	2.14	1800	2.34	1858	2.57	1979	3.11	2079	3.60					
4714	8009	1284	1740	2.11	1766	2.21	1816	2.40	1866	2.61	1922	2.85	2037	3.39							
4921	8361	1341	1815	2.40	1841	2.50	1886	2.69	1935	2.91	1985	3.14	2097	3.70							
5128	8713	1397	1889	2.70	1914	2.81	1958	3.01	2004	3.23	2052	3.47									
5335	9065	1454	1965	3.04	1989	3.15	2030	3.36	2072	3.57	2119	3.82									
5543	9417	1510	2039	3.40	2062	3.52	2102	3.73	2143	3.95											
5750	9769	1567	2113	3.79	2134	3.90	2174	4.12													

SQB-16 HP

Diámetro de Turbina	16-11/16"	Wheel Diameter	16-11/16"
Diámetro de Flecha	1 1/8"	Shaft Diameter	1 1/8"
Area de Descarga	3.67 Ft ²	Outlet Area	3.67 Ft ²
RPM Max	2400	Max RPM	2400
Velocidad Tangencial (FPM)	4.37 X RPM	Tip Speed (FPM)	4.37 X RPM
BHP Max	0.2022 (RPM/1000) ³	Max. BHP	0.2022 (RPM/1000) ³
Armazón Max de Motor	184T	Max. Motor Frame Size	184T
Peso aproximado (Sin Motor)	81 Lb	Approx. Ship WT.(Less Motor)	81 Lb

Caudal (Volumen)		Velocidad Descarga (Outlet Velocity)	Presión Estática en Pulgadas C.A. (Static Pressure in Inches W. G.)																	
			0.250"		0.500"		1.000"		1.500"		2.000"		2.500"		3.000"		4.000"		5.000"	
CFM	M ³ /HR	FPM	RPM	BHP	RPM	BHP	RPM	BHP	RPM	BHP	RPM	BHP	RPM	BHP	RPM	BHP	RPM	BHP	RPM	BHP
966	1641	263	742	0.08	892	0.14	1156	0.31	1383	0.54	1575	0.79								
1111	1887	303	803	0.10	944	0.17	1188	0.34	1402	0.56	1595	0.82	1764	1.11						
1256	2134	342	866	0.13	1003	0.20	1227	0.37	1429	0.59	1614	0.85	1784	1.15	1936	1.47				
1401	2380	382	933	0.16	1062	0.24	1271	0.42	1464	0.63	1638	0.89	1801	1.18	1954	1.51	2226	2.23		
1546	2626	421	1002	0.20	1123	0.29	1323	0.47	1504	0.69	1671	0.94	1825	1.23	1973	1.55	2247	2.29	2483	3.10
1691	2872	461	1073	0.25	1186	0.34	1381	0.53	1548	0.75	1709	1.01	1857	1.29	1997	1.61	2264	2.35	2504	3.18
1835	3118	500	1145	0.30	1250	0.40	1441	0.60	1598	0.82	1749	1.08	1894	1.37	2028	1.69	2283	2.41	2522	3.24
1980	3365	540	1220	0.37	1318	0.46	1500	0.68	1654	0.91	1794	1.17	1932	1.46	2065	1.78	2309	2.49	2550	3.35
2125	3611	579	1294	0.44	1386	0.54	1561	0.77	1712	1.02	1845	1.27	1976	1.56	2103	1.88	2341	2.60	2587	3.50
2270	3857	619	1368	0.52	1457	0.62	1623	0.86	1772	1.13	1901	1.39	2023	1.67	2144	1.99	2377	2.71		
2415	4103	658	1446	0.61	1528	0.72	1685	0.97	1832	1.24	1959	1.52	2076	1.81	2189	2.12	2415	2.85		
2560	4349	698	1521	0.71	1601	0.83	1750	1.08	1892	1.37	2018	1.66	2131	1.96	2239	2.27	2455	2.99		
2705	4595	737	1599	0.83	1674	0.95	1816	1.21	1953	1.51	2079	1.82	2190	2.12	2294	2.44				
2850	4842	776	1676	0.95	1748	1.08	1885	1.35	2015	1.66	2138	1.98	2249	2.30	2351	2.63				
2995	5088	816	1752	1.09	1823	1.22	1954	1.51	2079	1.82	2199	2.15	2309	2.49	2409	2.83				
3140	5334	855	1832	1.24	1897	1.38	2023	1.67	2143	1.99	2260	2.33	2369	2.69						
3284	5580	895	1910	1.41	1973	1.55	2095	1.86	2210	2.18	2322	2.53	2429	2.90						
3429	5826	934	1989	1.59	2049	1.74	2166	2.05	2277	2.39	2384	2.74								
3574	6073	974	2067	1.79	2125	1.94	2239	2.27	2345	2.61	2450	2.97								
3719	6319	1013	2144	1.99	2202	2.16	2310	2.49	2415	2.85	2468	3.04								

Los valores de caudal y presión están certificados para instalación tipo A: Succión y descarga libre sin ductos. Estos valores no incluyen los efectos de accesorios. Los valores de potencia (BHP) no incluyen las pérdidas por transmisión. (Performance certified for installation type A: Free inlet and free outlet. Performance rating does not include the effects of accessories. Power rating (BHP) does not include transmission losses.)

SQB

Especificaciones técnicas/Performance data

SQB-18

Diámetro de Turbina	18-9/16"	Wheel Diameter	18-9/16"
Diámetro de Flecha	1 3/8"	Shaft Diameter	1 3/8"
Area de Descarga	4.00 Ft ²	Outlet Area	4.00 Ft ²
RPM Max	1700	Max RPM	1700
Velocidad Tangencial (FPM)	4.86 X RPM	Tip Speed (FPM)	4.86 X RPM
BHP Max	0.6033 (RPM/1000) ³	Max. BHP	0.6033 (RPM/1000) ³
Armazón Max de Motor	184T	Max. Motor Frame Size	184T
Peso aproximado (Sin Motor)	103 Lb	Approx. Ship WT.(Less Motor)	103 Lb

Caudal (Volumen)		Velocidad Descarga (Outlet Velocity)	Presión Estática en Pulgadas C.A. (Static Pressure in Inches W. G.)																	
			0.125"		0.250"		0.500"		0.750"		1.000"		1.500"		2.000"		2.500"		3.000"	
CFM	M ³ /HR	FPM	RPM	BHP	RPM	BHP	RPM	BHP	RPM	BHP	RPM	BHP	RPM	BHP	RPM	BHP	RPM	BHP	RPM	BHP
2277	3869	569	671	0.18	735	0.24	871	0.40	983	0.57	1105	0.81								
2484	4220	621	721	0.23	778	0.28	907	0.45	1012	0.63	1120	0.85								
2691	4572	673	772	0.28	825	0.34	940	0.50	1049	0.70	1141	0.90	1345	1.47						
2898	4924	725	822	0.34	873	0.40	975	0.56	1086	0.77	1173	0.97	1360	1.52						
3105	5275	776	874	0.40	922	0.47	1015	0.63	1120	0.85	1209	1.07	1375	1.57	1552	2.25				
3312	5627	828	925	0.48	970	0.55	1057	0.71	1154	0.93	1246	1.17	1398	1.65	1566	2.32				
3519	5979	880	977	0.56	1021	0.64	1101	0.81	1189	1.01	1281	1.27	1430	1.76	1581	2.38	1737	3.16		
3726	6330	932	1029	0.66	1070	0.74	1148	0.91	1226	1.11	1315	1.37	1466	1.90	1601	2.48	1751	3.24		
3933	6682	983	1081	0.76	1122	0.85	1195	1.03	1267	1.23	1348	1.48	1503	2.05	1629	2.61	1766	3.32		
4140	7034	1035	1134	0.88	1172	0.97	1242	1.16	1311	1.36	1384	1.60	1539	2.20	1663	2.77	1785	3.43		
4347	7386	1087	1187	1.01	1224	1.11	1292	1.30	1355	1.50	1422	1.74	1574	2.35	1699	2.96	1812	3.59		
4554	7737	1139	1240	1.15	1275	1.25	1340	1.45	1402	1.66	1464	1.89	1607	2.50	1736	3.15				
4761	8089	1190	1292	1.30	1326	1.41	1390	1.62	1448	1.83	1507	2.07	1641	2.66	1772	3.35				
4968	8441	1242	1345	1.47	1379	1.58	1440	1.80	1497	2.02	1552	2.25	1676	2.84	1806	3.56				
5175	8792	1294	1400	1.65	1430	1.77	1490	1.99	1544	2.22	1598	2.46	1713	3.03						
5382	9144	1346	1453	1.85	1482	1.96	1540	2.20	1594	2.45	1644	2.68	1752	3.24						
5589	9496	1397	1507	2.07	1535	2.18	1591	2.43	1643	2.68	1693	2.93	1794	3.48						
5796	9847	1449	1561	2.29	1587	2.41	1641	2.67	1692	2.92	1740	3.18								
6003	10199	1501	1615	2.54	1641	2.67	1693	2.93	1743	3.19	1788	3.45								
6210	10551	1553	1667	2.80	1694	2.93	1744	3.20	1792	3.47	1838	3.74								

SQB-18 HP

Diámetro de Turbina	18-9/16"	Wheel Diameter	18-9/16"
Diámetro de Flecha	1 3/8"	Shaft Diameter	1 3/8"
Area de Descarga	4.00 Ft ²	Outlet Area	4.00 Ft ²
RPM Max	1900	Max RPM	1900
Velocidad Tangencial (FPM)	4.86 X RPM	Tip Speed (FPM)	4.86 X RPM
BHP Max	0.3501 (RPM/1000) ³	Max. BHP	0.3501 (RPM/1000) ³
Armazón Max de Motor	184T	Max. Motor Frame Size	184T
Peso aproximado (Sin Motor)	103 Lb	Approx. Ship WT.(Less Motor)	103 Lb

Caudal (Volumen)		Velocidad Descarga (Outlet Velocity)	Presión Estática en Pulgadas C.A. (Static Pressure in Inches W. G.)																	
			0.250"		0.500"		1.000"		1.500"		2.000"		2.500"		3.000"		4.000"		5.000"	
CFM	M ³ /HR	FPM	RPM	BHP	RPM	BHP	RPM	BHP	RPM	BHP	RPM	BHP	RPM	BHP	RPM	BHP	RPM	BHP	RPM	BHP
1174	1994	293	631	0.09	789	0.17	1054	0.41	1266	0.71	1444	1.05								
1345	2285	336	674	0.11	820	0.19	1071	0.43	1281	0.74	1458	1.09	1615	1.47						
1516	2576	379	719	0.13	857	0.22	1094	0.46	1297	0.76	1474	1.12	1631	1.52	1771	1.95				
1687	2866	422	767	0.16	898	0.25	1120	0.49	1316	0.80	1490	1.16	1646	1.56	1787	2.00	2039	2.97		
1858	3157	465	819	0.19	941	0.29	1150	0.53	1338	0.84	1507	1.20	1662	1.61	1802	2.05	2052	3.03		
2029	3448	507	873	0.23	985	0.33	1185	0.58	1364	0.89	1528	1.25	1678	1.65	1818	2.10	2068	3.09		
2201	3739	550	927	0.28	1031	0.38	1224	0.64	1393	0.95	1552	1.31	1698	1.71	1834	2.16	2083	3.16		
2372	4029	593	984	0.33	1080	0.44	1265	0.71	1426	1.02	1578	1.38	1720	1.78	1854	2.23	2100	3.24		
2543	4320	636	1040	0.39	1131	0.51	1308	0.78	1462	1.09	1607	1.45	1745	1.86	1875	2.31	2124	3.35		
2714	4611	678	1098	0.46	1183	0.58	1351	0.86	1502	1.19	1639	1.54	1772	1.95	1899	2.40	2151	3.48		
2885	4902	721	1156	0.54	1237	0.66	1395	0.95	1544	1.29	1675	1.65	1802	2.05	1925	2.50				
3056	5193	764	1215	0.63	1292	0.76	1441	1.05	1585	1.39	1714	1.76	1835	2.16	1954	2.61				
3227	5483	807	1274	0.72	1348	0.86	1490	1.16	1628	1.51	1755	1.89	1871	2.29	1985	2.74				
3399	5774	850	1334	0.83	1405	0.97	1539	1.28	1672	1.64	1796	2.03	1910	2.44	2019	2.88				
3570	6065	892	1392	0.94	1462	1.09	1590	1.41	1717	1.77	1839	2.18	1951	2.60	2055	3.04				
3741	6356	935	1454	1.08	1518	1.23	1642	1.55	1763	1.92	1882	2.33	1992	2.77						
3912	6646	978	1515	1.22	1577	1.37	1696	1.71	1811	2.08	1925	2.50	2034	2.95						
4083	6937	1021	1575	1.37	1635	1.53	1748	1.87	1859	2.25	1970	2.68								
4254	7228	1064	1635	1.53	1693	1.70	1804	2.06	1910	2.44	2016	2.87								
4425	7519	1106	1695	1.70	1752	1.88	1858	2.25	1961	2.64										

Los valores de caudal y presión están certificados para instalación tipo A: Succión y descarga libre sin ductos. Estos valores no incluyen los efectos de accesorios. Los valores de potencia (BHP) no incluyen las pérdidas por transmisión. (Performance certified for installation type A: Free inlet and free outlet. Performance rating does not include the effects of accessories. Power rating (BHP) does not include transmission losses.)

SQB

Especificaciones técnicas/Performance data

SQB-20

Diámetro de Turbina	20-7/16"	Wheel Diameter	20-7/16"
Diámetro de Flecha	1 3/8"	Shaft Diameter	1 3/8"
Área de Descarga	5.44 Ft ²	Outlet Area	5.44 Ft ²
RPM Max	1350	Max RPM	1350
Velocidad Tangencial (FPM)	5.35 X RPM	Tip Speed (FPM)	5.35 X RPM
BHP Max	1.3075 (RPM/1000) ³	Max. BHP	1.3075 (RPM/1000) ³
Armazón Max de Motor	184T	Max. Motor Frame Size	184T
Peso aproximado (Sin Motor)	143 Lb	Approx. Ship WT.(Less Motor)	143 Lb

Caudal (Volumen)		Velocidad Descarga (Outlet Velocity)	Presión Estática en Pulgadas C.A. (Static Pressure in Inches W. G.)																	
			0.125"		0.250"		0.500"		0.750"		1.000"		1.500"		2.000"		2.500"		3.000"	
CFM	M ³ /HR	FPM	RPM	BHP	RPM	BHP	RPM	BHP	RPM	BHP	RPM	BHP	RPM	BHP	RPM	BHP	RPM	BHP	RPM	BHP
2757	4685	507	518	0.18	579	0.25	676	0.40	772	0.60	867	0.85								
2999	5096	551	552	0.22	611	0.30	704	0.46	791	0.65	879	0.89								
3241	5507	596	586	0.26	643	0.35	733	0.51	813	0.70	895	0.94								
3483	5918	640	622	0.31	676	0.40	763	0.58	839	0.77	913	0.99	1066	1.58						
3725	6329	685	659	0.37	707	0.46	794	0.66	867	0.85	936	1.07	1079	1.64						
3967	6740	729	696	0.44	740	0.53	827	0.74	896	0.94	961	1.16	1095	1.71	1227	2.41				
4209	7150	774	733	0.52	774	0.61	859	0.83	926	1.04	989	1.26	1113	1.80	1239	2.49				
4451	7561	818	771	0.60	809	0.69	891	0.92	958	1.15	1018	1.38	1134	1.91	1254	2.58				
4692	7972	863	809	0.69	844	0.79	923	1.03	989	1.26	1048	1.50	1159	2.04	1270	2.68				
4934	8383	907	847	0.80	880	0.89	955	1.14	1022	1.39	1078	1.64	1185	2.18	1289	2.80				
5176	8794	951	886	0.91	917	1.01	987	1.26	1054	1.53	1109	1.78	1212	2.33	1312	2.96				
5418	9205	996	923	1.03	953	1.13	1020	1.39	1085	1.67	1141	1.94	1241	2.50						
5660	9616	1040	962	1.16	991	1.27	1053	1.53	1118	1.83	1173	2.11	1270	2.68						
5902	10027	1085	1001	1.31	1029	1.42	1086	1.68	1150	1.99	1205	2.29	1301	2.88						
6144	10438	1129	1040	1.47	1066	1.59	1121	1.84	1182	2.16	1237	2.48								
6386	10849	1174	1080	1.65	1103	1.75	1156	2.02	1213	2.34	1270	2.68								
6627	11260	1218	1119	1.83	1142	1.95	1192	2.21	1246	2.53	1302	2.88								
6869	11671	1263	1158	2.03	1180	2.15	1227	2.42	1280	2.74	1333	3.10								
7111	12082	1307	1197	2.24	1219	2.37	1264	2.64	1314	2.96										
7353	12493	1352	1236	2.47	1256	2.59	1300	2.88	1347	3.20										

SQB-20 HP

Diámetro de Turbina	20-7/16"	Wheel Diameter	20-7/16"
Diámetro de Flecha	1 3/8"	Shaft Diameter	1 3/8"
Área de Descarga	5.44 Ft ²	Outlet Area	5.44 Ft ²
RPM Max	1650	Max RPM	1650
Velocidad Tangencial (FPM)	5.35 X RPM	Tip Speed (FPM)	5.35 X RPM
BHP Max	0.7716 (RPM/1000) ³	Max. BHP	0.7716 (RPM/1000) ³
Armazón Max de Motor	184T	Max. Motor Frame Size	184T
Peso aproximado (Sin Motor)	143 Lb	Approx. Ship WT.(Less Motor)	143 Lb

Caudal (Volumen)		Velocidad Descarga (Outlet Velocity)	Presión Estática en Pulgadas C.A. (Static Pressure in Inches W. G.)																	
			0.250"		0.500"		1.000"		1.500"		2.000"		2.500"		3.000"		4.000"		5.000"	
CFM	M ³ /HR	FPM	RPM	BHP	RPM	BHP	RPM	BHP	RPM	BHP	RPM	BHP	RPM	BHP	RPM	BHP	RPM	BHP	RPM	BHP
1439	2444	264	510	0.10	650	0.21	877	0.52	1049	0.89										
1630	2770	300	541	0.12	667	0.23	890	0.54	1062	0.92	1208	1.36								
1822	3096	335	573	0.15	690	0.25	903	0.57	1077	0.96	1222	1.41	1349	1.90	1466	2.43				
2014	3422	370	605	0.17	717	0.28	917	0.59	1090	1.00	1235	1.45	1363	1.95	1478	2.49				
2206	3747	405	638	0.20	748	0.32	933	0.63	1103	1.04	1249	1.51	1376	2.01	1491	2.56	1697	3.77		
2398	4073	441	673	0.24	780	0.37	952	0.67	1116	1.07	1263	1.55	1390	2.07	1505	2.63	1713	3.88		
2589	4399	476	709	0.28	811	0.41	976	0.72	1131	1.12	1275	1.60	1404	2.13	1519	2.70	1730	4.00		
2781	4725	511	747	0.32	844	0.46	1003	0.78	1149	1.17	1289	1.65	1417	2.20	1532	2.78				
2973	5051	546	785	0.37	877	0.52	1034	0.85	1169	1.23	1304	1.71	1430	2.25	1545	2.85				
3165	5377	582	825	0.43	910	0.58	1064	0.93	1193	1.31	1320	1.78	1443	2.32	1558	2.92				
3357	5703	617	864	0.50	945	0.65	1096	1.02	1220	1.40	1340	1.86	1458	2.39	1571	2.99				
3548	6029	652	904	0.57	981	0.73	1129	1.11	1250	1.51	1363	1.95	1476	2.48	1586	3.08				
3740	6354	688	945	0.65	1018	0.82	1160	1.20	1280	1.62	1388	2.06	1496	2.58						
3932	6680	723	985	0.74	1056	0.91	1192	1.31	1311	1.74	1416	2.19	1518	2.70						
4124	7006	758	1026	0.83	1094	1.01	1224	1.42	1344	1.87	1445	2.33	1543	2.84						
4316	7332	793	1067	0.94	1133	1.12	1257	1.53	1375	2.01	1476	2.48	1570	2.99						
4507	7658	829	1108	1.05	1172	1.24	1291	1.66	1407	2.15	1508	2.64								
4699	7984	864	1149	1.17	1211	1.37	1326	1.80	1438	2.30	1539	2.81								
4891	8310	899	1191	1.30	1251	1.51	1361	1.95	1471	2.46										
5083	8636	934	1233	1.45	1291	1.66	1399	2.11	1503	2.62										

Los valores de caudal y presión están certificados para instalación tipo A: Succión y descarga libre sin ductos. Estos valores no incluyen los efectos de accesorios. Los valores de potencia (BHP) no incluyen las pérdidas por transmisión. (Performance certified for installation type A: Free inlet and free outlet. Performance rating does not include the effects of accessories. Power rating (BHP) does not include transmission losses.)

SQB

Especificaciones técnicas/Performance data

SQB-22

Diámetro de Turbina	22-9/16"	Wheel Diameter	22-9/16"
Diámetro de Flecha	1 5/8"	Shaft Diameter	1 5/8"
Área de Descarga	7.11 Ft ²	Outlet Area	7.11 Ft ²
RPM Max	1300	Max RPM	1300
Velocidad Tangencial (FPM)	5.91 X RPM	Tip Speed (FPM)	5.91 X RPM
BHP Max	1.6966 (RPM/1000) ³	Max. BHP	1.6966 (RPM/1000) ³
Armazón Max de Motor	184T	Max. Motor Frame Size	184T
Peso aproximado (Sin Motor)	183 Lb	Approx. Ship WT.(Less Motor)	183 Lb

Caudal (Volumen)		Velocidad Descarga (Outlet Velocity)	Presión Estática en Pulgadas C.A. (Static Pressure in Inches W. G.)																	
			0.125"		0.250"		0.500"		0.750"		1.000"		1.500"		2.000"		2.500"		3.000"	
CFM	M ³ /HR	FPM	RPM	BHP	RPM	BHP	RPM	BHP	RPM	BHP	RPM	BHP	RPM	BHP	RPM	BHP	RPM	BHP	RPM	BHP
3406	5787	479	523	0.24	585	0.34	684	0.54	782	0.81	880	1.15								
3773	6410	531	565	0.31	624	0.41	718	0.63	805	0.89	894	1.21								
4140	7033	582	608	0.38	664	0.50	755	0.73	834	0.99	914	1.30								
4506	7656	634	653	0.47	704	0.59	793	0.85	868	1.11	940	1.41	1090	2.20						
4873	8280	685	698	0.58	745	0.70	832	0.98	904	1.25	971	1.55	1108	2.31	1243	3.26				
5240	8903	737	746	0.70	787	0.83	872	1.12	941	1.41	1004	1.72	1130	2.45	1259	3.39				
5607	9526	789	792	0.84	830	0.97	912	1.29	980	1.60	1040	1.91	1157	2.63	1277	3.53	1396	4.61		
5974	10149	840	839	1.00	874	1.13	952	1.46	1019	1.79	1077	2.12	1188	2.85	1299	3.72	1411	4.77	1520	5.96
6340	10772	892	886	1.18	919	1.32	991	1.65	1059	2.01	1116	2.36	1222	3.09	1325	3.95	1430	4.96	1540	6.20
6707	11396	943	933	1.38	964	1.52	1031	1.86	1098	2.25	1155	2.61	1257	3.37	1354	4.21	1452	5.19	1568	6.54
7074	12019	995	981	1.60	1010	1.75	1072	2.09	1138	2.50	1195	2.89	1294	3.67	1386	4.52	1478	5.48		
7441	12642	1047	1029	1.85	1056	2.00	1114	2.35	1178	2.77	1234	3.19	1331	4.00	1421	4.87	1507	5.81		
7808	13265	1098	1078	2.13	1102	2.27	1157	2.63	1218	3.06	1274	3.51	1370	4.36	1456	5.24				
8174	13888	1150	1127	2.43	1150	2.58	1201	2.94	1257	3.37	1314	3.85	1409	4.74	1493	5.65				
8541	14511	1201	1175	2.75	1197	2.91	1245	3.27	1298	3.71	1354	4.21	1448	5.15						
8908	15135	1253	1222	3.10	1245	3.28	1290	3.64	1340	4.08	1392	4.58	1488	5.59						
9275	15758	1304	1271	3.48	1292	3.66	1336	4.05	1383	4.49	1433	4.99	1528	6.05						
9642	16381	1356	1319	3.89	1339	4.07	1381	4.47	1425	4.91	1474	5.43								
10008	17004	1408	1366	4.32	1386	4.51	1427	4.93	1470	5.39	1515	5.89								
10375	17627	1459	1415	4.81	1435	5.01	1475	5.44	1514	5.89										

SQB-22 HP

Diámetro de Turbina	22-9/16"	Wheel Diameter	22-9/16"
Diámetro de Flecha	1 5/8"	Shaft Diameter	1 5/8"
Área de Descarga	7.11 Ft ²	Outlet Area	7.11 Ft ²
RPM Max	1600	Max RPM	1600
Velocidad Tangencial (FPM)	5.91 X RPM	Tip Speed (FPM)	5.91 X RPM
BHP Max	0.9815 (RPM/1000) ³	Max. BHP	0.9815 (RPM/1000) ³
Armazón Max de Motor	184T	Max. Motor Frame Size	184T
Peso aproximado (Sin Motor)	183 Lb	Approx. Ship WT.(Less Motor)	183 Lb

Caudal (Volumen)		Velocidad Descarga (Outlet Velocity)	Presión Estática en Pulgadas C.A. (Static Pressure in Inches W. G.)																	
			0.250"		0.500"		1.000"		1.500"		2.000"		2.500"		3.000"		4.000"		5.000"	
CFM	M ³ /HR	FPM	RPM	BHP	RPM	BHP	RPM	BHP	RPM	BHP	RPM	BHP	RPM	BHP	RPM	BHP	RPM	BHP	RPM	BHP
1881	3196	265	532	0.15	669	0.29	900	0.72	1076	1.22	1227	1.81								
2195	3728	309	574	0.19	695	0.33	918	0.76	1095	1.29	1243	1.88	1374	2.55						
2508	4261	353	617	0.23	731	0.38	936	0.80	1113	1.35	1261	1.97	1391	2.64	1510	3.38				
2822	4794	397	661	0.28	772	0.45	958	0.86	1131	1.42	1279	2.05	1410	2.75	1527	3.50	1738	5.15		
3135	5326	441	709	0.35	815	0.53	986	0.94	1149	1.49	1297	2.14	1429	2.86	1546	3.63	1754	5.30	1939	7.16
3449	5859	485	759	0.43	857	0.62	1021	1.04	1171	1.57	1315	2.23	1446	2.97	1564	3.75	1773	5.47	1960	7.39
3762	6392	529	810	0.52	901	0.72	1061	1.17	1199	1.69	1335	2.33	1463	3.07	1582	3.88	1791	5.64	1980	7.62
4076	6924	573	863	0.63	946	0.83	1102	1.32	1232	1.84	1359	2.46	1482	3.19	1598	4.01	1810	5.82		
4389	7457	617	915	0.75	993	0.96	1145	1.48	1270	2.01	1387	2.62	1504	3.34	1617	4.15	1826	5.98		
4703	7990	661	969	0.89	1044	1.12	1187	1.64	1310	2.21	1420	2.81	1531	3.52	1638	4.31	1844	6.15		
5016	8522	705	1024	1.05	1094	1.29	1230	1.83	1353	2.43	1458	3.04	1561	3.74	1663	4.51				
5330	9055	750	1078	1.23	1146	1.48	1274	2.03	1395	2.66	1499	3.31	1595	3.98	1691	4.75				
5643	9587	794	1133	1.43	1197	1.68	1319	2.25	1438	2.92	1540	3.58	1633	4.28	1724	5.03				
5957	10120	838	1189	1.65	1250	1.92	1366	2.50	1479	3.18	1583	3.89	1673	4.60	1760	5.35				
6270	10653	882	1243	1.89	1303	2.17	1414	2.77	1522	3.46	1625	4.22	1715	4.95	1799	5.71				
6584	11185	926	1299	2.15	1356	2.45	1463	3.07	1566	3.77	1667	4.55	1758	5.33						
6897	11718	970	1356	2.45	1410	2.75	1513	3.40	1612	4.11	1710	4.91	1799	5.72						
7211	12251	1014	1413	2.77	1465	3.09	1565	3.76	1658	4.48	1753	5.29								
7524	12783	1058	1469	3.11	1519	3.44	1616	4.14	1706	4.87	1796	5.69								
7838	13316	1102	1525	3.48	1574	3.82	1667	4.55	1755	5.30										

Los valores de caudal y presión están certificados para instalación tipo A: Succión y descarga libre sin ductos. Estos valores no incluyen los efectos de accesorios. Los valores de potencia (BHP) no incluyen las pérdidas por transmisión. (Performance certified for installation type A: Free inlet and free outlet. Performance rating does not include the effects of accessories. Power rating (BHP) does not include transmission losses.)

SQB

Especificaciones técnicas/Performance data

SQB-24

Diámetro de Turbina	24-5/8"	Wheel Diameter	24-5/8"
Diámetro de Flecha	1 5/8"	Shaft Diameter	1 5/8"
Área de Descarga	8.51 Ft ²	Outlet Area	8.51 Ft ²
RPM Max	1300	Max RPM	1300
Velocidad Tangencial (FPM)	6.45 X RPM	Tip Speed (FPM)	6.45 X RPM
BHP Max	2.5072 (RPM/1000) ³	Max. BHP	2.5072 (RPM/1000) ³
Armazón Max de Motor	213T	Max. Motor Frame Size	213T
Peso aproximado (Sin Motor)	198 Lb	Approx. Ship WT.(Less Motor)	198 Lb

Caudal (Volumen)		Velocidad Descarga (Outlet Velocity)	Presión Estática en Pulgadas C.A. (Static Pressure in Inches W. G.)																		
			0.125"		0.250"		0.500"		0.750"		1.000"		1.500"		2.000"		2.500"		3.000"		
CFM	M ³ /HR	FPM	RPM	BHP	RPM	BHP	RPM	BHP	RPM	BHP	RPM	BHP	RPM	BHP	RPM	BHP	RPM	BHP	RPM	BHP	
4360	7407	512	494	0.30	552	0.42	644	0.67	731	0.98	0	0.00									
4879	8289	573	540	0.40	593	0.52	680	0.79	759	1.09	838	1.48									
5398	9171	634	587	0.51	635	0.64	720	0.93	791	1.24	862	1.61	1003	2.53							
5917	10052	695	635	0.64	678	0.78	760	1.10	827	1.42	892	1.78	1022	2.68							
6436	10934	756	684	0.80	722	0.95	802	1.29	867	1.63	926	1.99	1046	2.87	1164	3.95					
6955	11816	817	735	0.99	768	1.14	843	1.50	908	1.87	964	2.25	1074	3.11	1184	4.17	1291	5.40			
7474	12698	878	785	1.21	815	1.36	884	1.73	948	2.14	1004	2.53	1107	3.40	1208	4.42	1311	5.65			
7993	13579	939	835	1.46	863	1.61	926	1.99	990	2.43	1044	2.85	1142	3.73	1236	4.74	1333	5.94	1427	7.28	
8512	14461	1000	886	1.74	912	1.90	970	2.29	1031	2.74	1085	3.20	1179	4.11	1269	5.12	1358	6.27	1448	7.61	
9031	15343	1061	936	2.06	960	2.22	1015	2.62	1072	3.09	1126	3.58	1218	4.53	1303	5.55	1387	6.69	1472	7.99	
9550	16225	1122	988	2.41	1011	2.59	1060	2.98	1114	3.47	1167	3.98	1258	5.00	1340	6.04	1419	7.16			
10069	17107	1183	1040	2.82	1061	2.99	1107	3.40	1157	3.88	1209	4.43	1299	5.50	1378	6.56	1454	7.71			
10588	17988	1244	1091	3.26	1110	3.43	1154	3.85	1200	4.34	1249	4.89	1341	6.04	1417	7.14					
11107	18870	1305	1142	3.74	1161	3.92	1202	4.35	1245	4.84	1291	5.39	1381	6.61	1458	7.77					
11626	19752	1366	1193	4.26	1212	4.46	1250	4.89	1291	5.40	1335	5.96	1423	7.22							
12145	20634	1427	1245	4.83	1262	5.04	1299	5.49	1337	5.99	1378	6.56	1463	7.86							
12664	21515	1488	1295	5.44	1312	5.67	1347	6.12	1384	6.64	1423	7.23									
13183	22397	1549	1347	6.13	1363	6.36	1397	6.83	1432	7.36	1468	7.93									
13702	23279	1610	1398	6.85	1415	7.10	1447	7.59	1479	8.10											
14221	24161	1671	1449	7.63	1467	7.91	1496	8.39													

SQB-24 HP

Diámetro de Turbina	24-5/8"	Wheel Diameter	24-5/8"
Diámetro de Flecha	1 5/8"	Shaft Diameter	1 5/8"
Área de Descarga	8.51 Ft ²	Outlet Area	8.51 Ft ²
RPM Max	1600	Max RPM	1600
Velocidad Tangencial (FPM)	6.45 X RPM	Tip Speed (FPM)	6.45 X RPM
BHP Max	1.6031 (RPM/1000) ³	Max. BHP	1.6031 (RPM/1000) ³
Armazón Max de Motor	213T	Max. Motor Frame Size	213T
Peso aproximado (Sin Motor)	198 Lb	Approx. Ship WT.(Less Motor)	198 Lb

Caudal (Volumen)		Velocidad Descarga (Outlet Velocity)	Presión Estática en Pulgadas C.A. (Static Pressure in Inches W. G.)																	
			0.250"		0.500"		1.000"		1.500"		2.000"		2.500"		3.000"		4.000"		5.000"	
CFM	M ³ /HR	FPM	RPM	BHP	RPM	BHP	RPM	BHP	RPM	BHP	RPM	BHP	RPM	BHP	RPM	BHP	RPM	BHP	RPM	BHP
2020	3432	237	457	0.15	597	0.34	808	0.85	972	1.47										
2486	4224	292	498	0.20	621	0.38	828	0.91	989	1.55	1126	2.29	1249	3.12	1363	4.06				
2953	5016	347	543	0.26	654	0.45	847	0.97	1008	1.64	1145	2.40	1265	3.24	1374	4.16	1573	6.24		
3419	5809	402	592	0.33	694	0.54	871	1.06	1028	1.74	1163	2.52	1283	3.39	1391	4.32	1585	6.39	1759	8.72
3885	6601	457	646	0.43	738	0.64	901	1.17	1049	1.85	1183	2.65	1302	3.54	1410	4.49	1603	6.60	1772	8.92
4351	7393	511	703	0.56	785	0.77	937	1.32	1076	2.00	1205	2.80	1321	3.70	1429	4.67	1621	6.83	1790	9.19
4817	8185	566	762	0.71	836	0.94	979	1.50	1107	2.18	1229	2.97	1343	3.88	1448	4.87	1640	7.07	1809	9.50
5284	8977	621	821	0.89	889	1.12	1022	1.71	1144	2.40	1258	3.19	1367	4.09	1470	5.09	1659	7.33	1828	9.79
5750	9769	676	881	1.10	945	1.35	1068	1.95	1184	2.66	1291	3.45	1395	4.35	1494	5.34	1679	7.59		
6216	10561	730	940	1.33	1002	1.61	1116	2.23	1228	2.97	1329	3.76	1426	4.65	1522	5.65	1701	7.89		
6682	11353	785	1002	1.61	1060	1.91	1166	2.54	1272	3.30	1369	4.12	1462	5.01	1552	5.99	1726	8.24		
7148	12145	840	1061	1.91	1119	2.25	1218	2.90	1318	3.67	1413	4.52	1501	5.43	1587	6.40	1753	8.64		
7615	12937	895	1123	2.27	1178	2.62	1272	3.30	1365	4.08	1457	4.96	1543	5.89	1625	6.88				
8081	13729	950	1183	2.66	1237	3.04	1328	3.76	1415	4.54	1503	5.44	1586	6.40	1665	7.40				
8547	14521	1004	1245	3.09	1298	3.50	1385	4.26	1467	5.06	1550	5.97	1631	6.95	1708	7.98				
9013	15313	1059	1308	3.59	1358	4.01	1444	4.82	1520	5.63	1599	6.55	1677	7.56						
9479	16106	1114	1369	4.12	1418	4.57	1502	5.43	1575	6.26	1649	7.19	1724	8.21						
9946	16898	1169	1432	4.70	1478	5.18	1560	6.08	1631	6.95	1701	7.88								
10412	17690	1223	1493	5.34	1539	5.85	1619	6.80	1688	7.71	1754	8.66								
10878	18482	1278	1556	6.04	1601	6.57	1678	7.57	1746	8.53										

Los valores de caudal y presión están certificados para instalación tipo A: Succión y descarga libre sin ductos. Estos valores no incluyen los efectos de accesorios. Los valores de potencia (BHP) no incluyen las pérdidas por transmisión. (Performance certified for installation type A: Free inlet and free outlet. Performance rating does not include the effects of accessories. Power rating (BHP) does not include transmission losses.)

SQB

Curvas de operación/Performance Curves

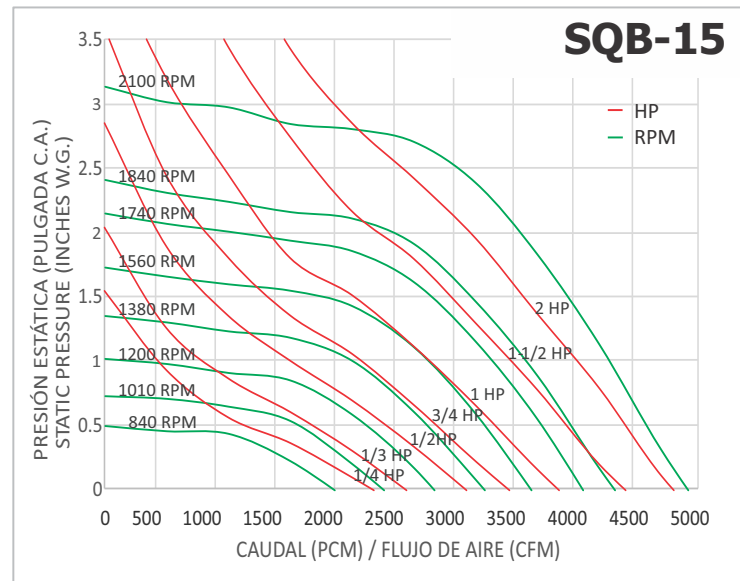
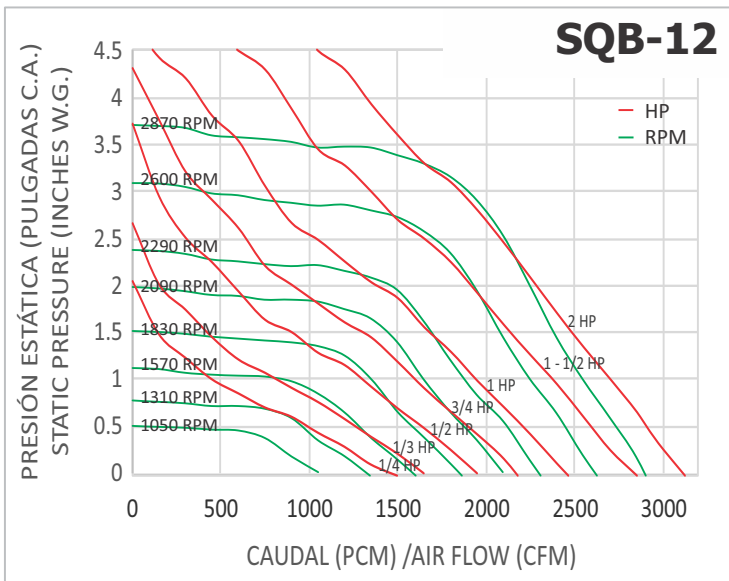
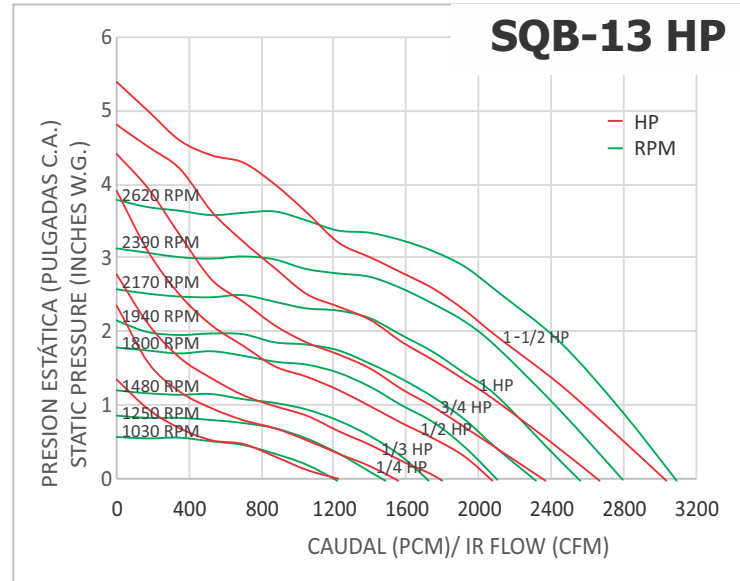
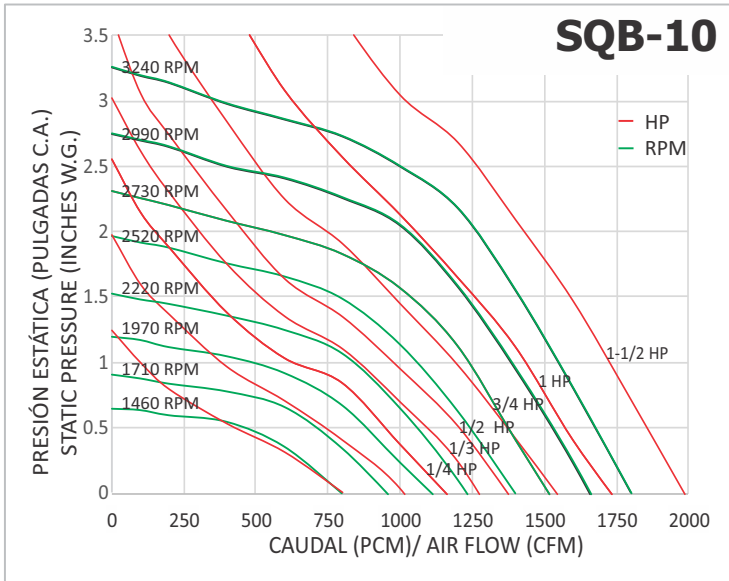
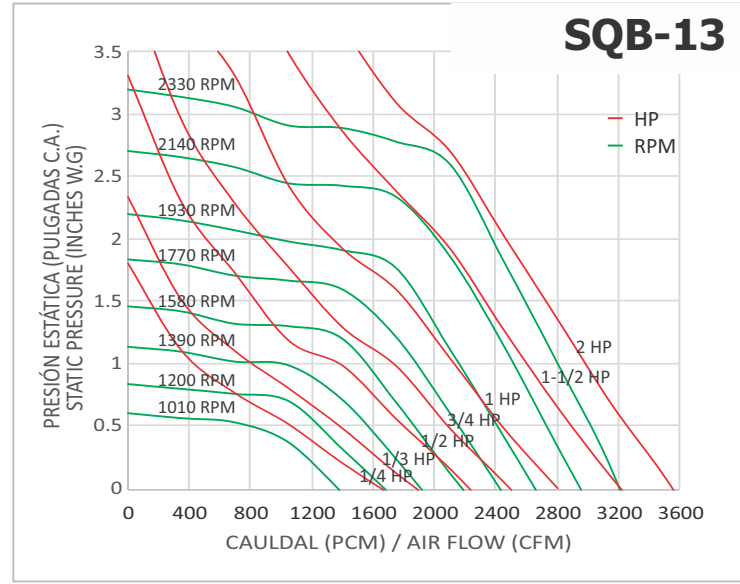
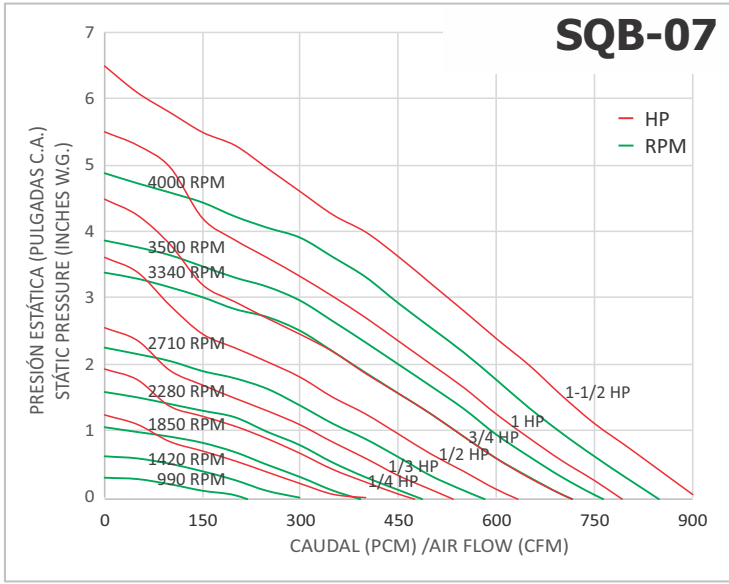

Todas las capacidades están basadas en la densidad estándar del aire de 0.075 lbs/ft³ @ 70°F y 0 pies de elevación: 1.2 kg/m³@21°C y 0 mt. / (All capacities are based on the standard air density of 0.075 lbs/ft³ @ 70 °F and 0 ft Elevation: 1.2 kg/M³ @ 21 °c and 0 Mt.)
 Datos obtenidos de acuerdo a la norma AMCA ESTANDAR 301. / (Information obtained according to the AMCA STANDARD 301)

SQB

Curvas de operación/Performance Curves

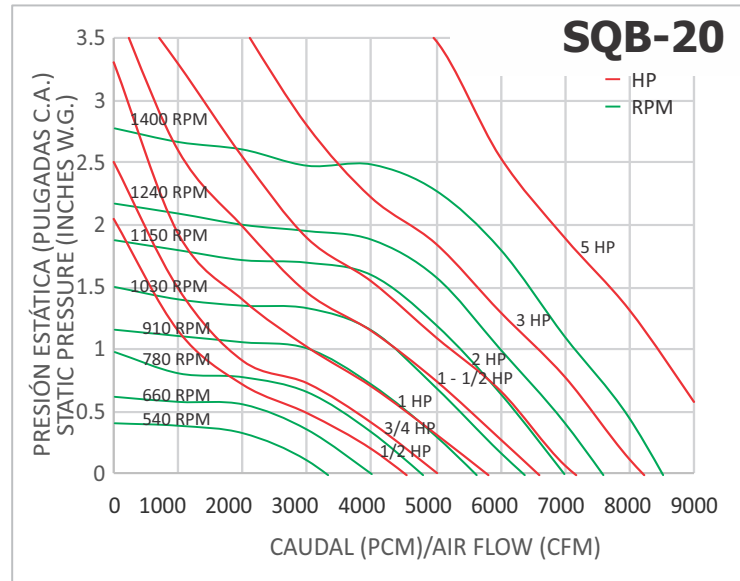
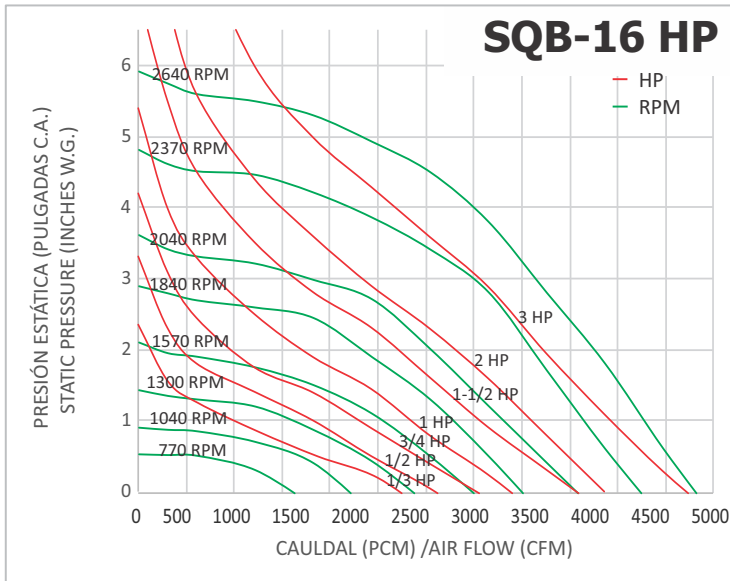
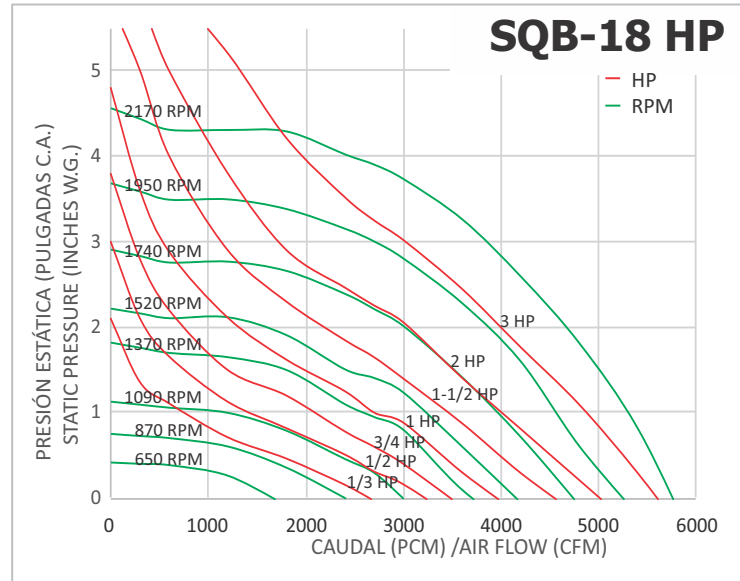
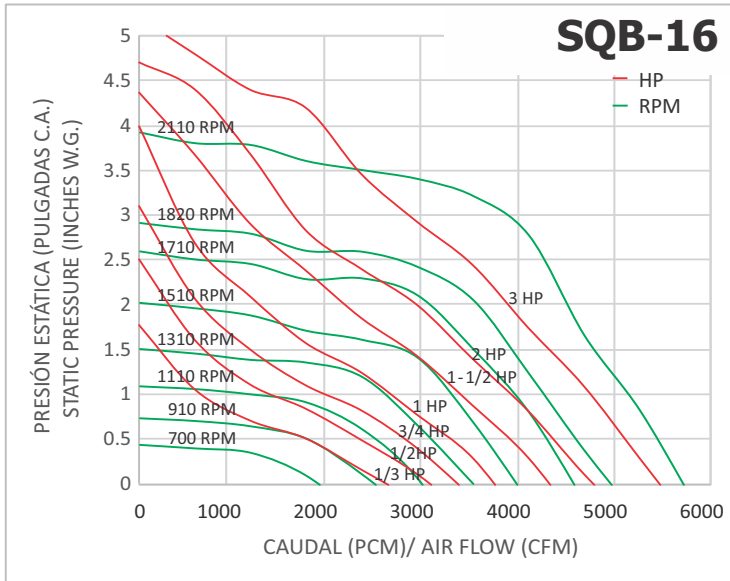
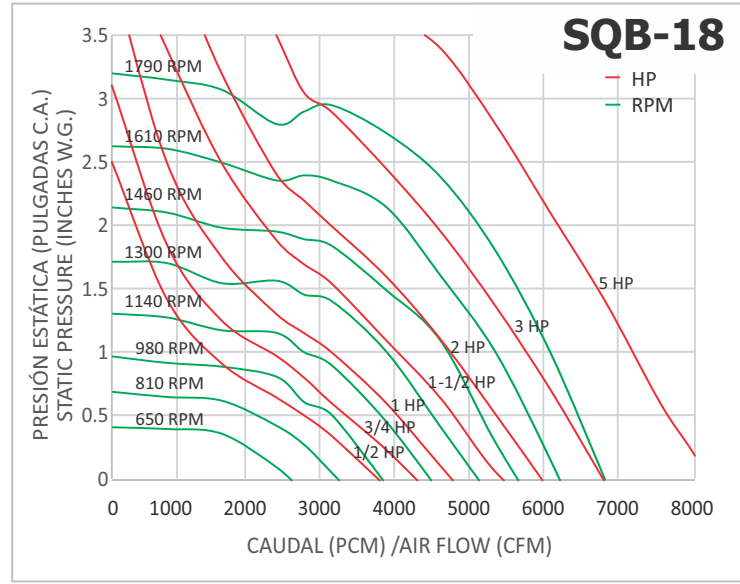
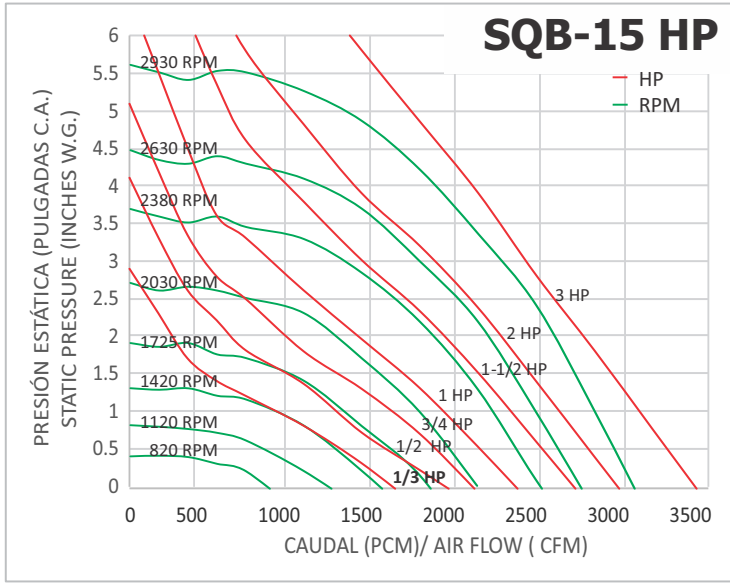

Todas las capacidades estan basadas en la densidad estandar del aire de 0.075 lbs/ft³ @ 70°F y 0 pies de elevación: 1.2 kg/m³@21°C y 0 mt. / (All capacities are based on the standard air density of 0.075 lbs/ft³ @ 70 °F and 0 ft Elevation: 1.2 kg/M³ @ 21 °c and 0 Mt.)
 Datos obtenidos de acuerdo a la norma AMCA ESTANDAR 301. / (Information obtained according to the AMCA STANDARD 301)

SQB

Curvas de operación/Performance Curves

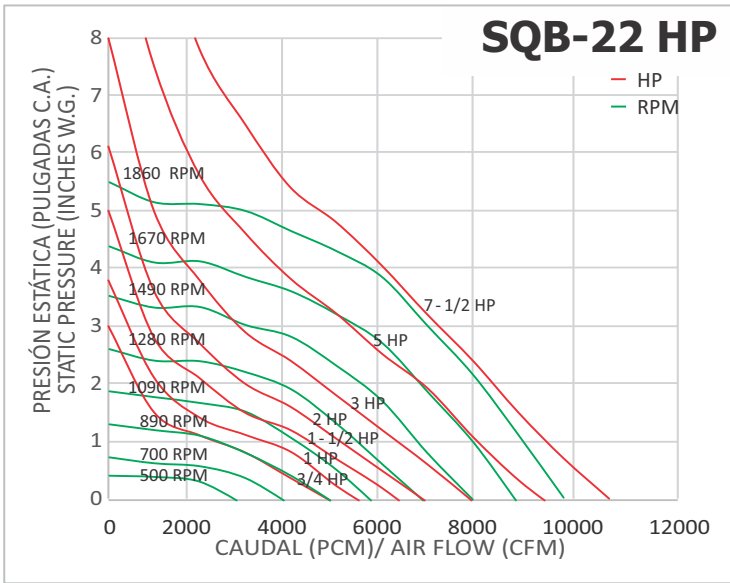
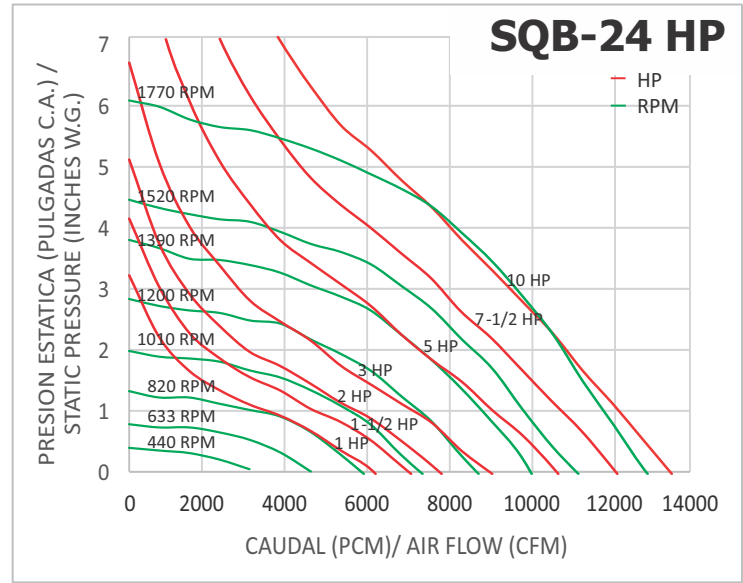
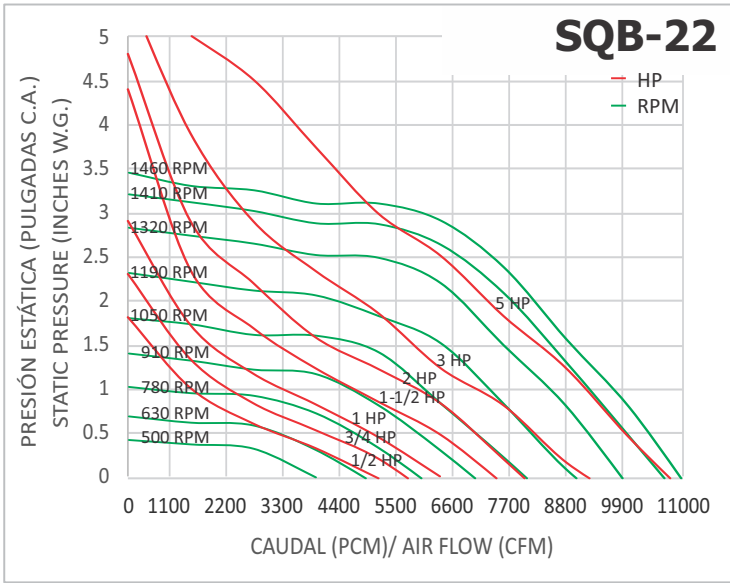
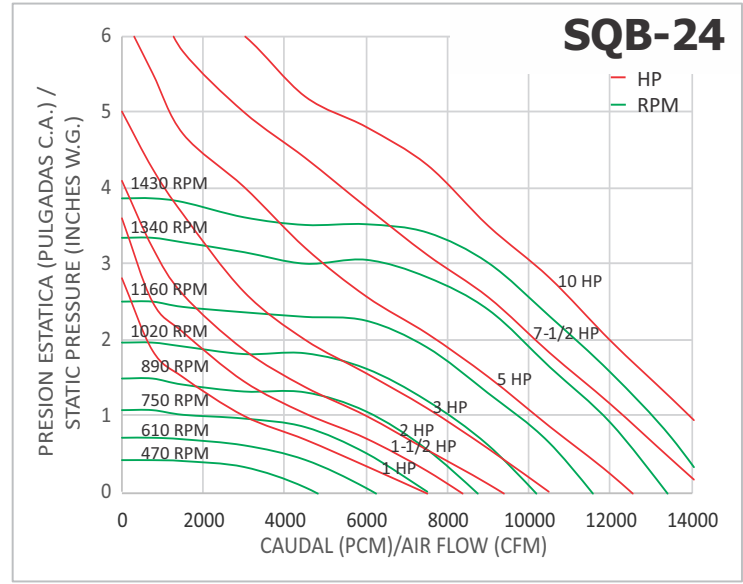
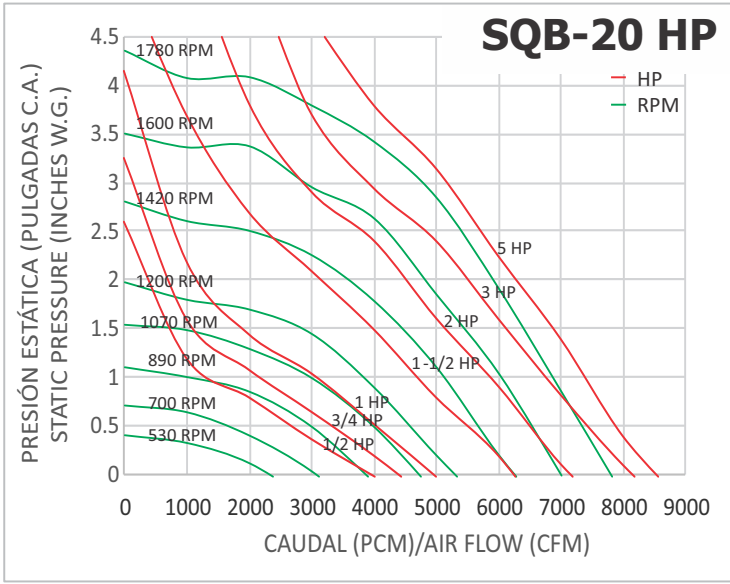

Todas las capacidades estan basadas en la densidad estandar del aire de 0.075 lbs/ft³ @ 70°F y 0 pies de elevación: 1.2 kg/m³@21°C y 0 mt. / (All capacities are based on the standard air density of 0.075 lbs/ft³ @ 70 °F and 0 ft Elevation: 1.2 kg/m³ @ 21 °c and 0 Mt.)
 Datos obtenidos de acuerdo a la norma AMCA ESTANDAR 301. / (Information obtained according to the AMCA STANDARD 301)

SQB

Espectro de potencia sonora (Sound Pressure Level Ratings)

SQB-07

RPM	Hz	63	125	250	500	1K	2K	4K	8K	LWA	dB (A)
	1529	70	72	67	58	56	49	45	37	65	53
	1833	77	78	74	68	64	57	52	45	71	59
	2057	76	80	75	70	65	58	53	47	73	61
	2683	77	86	83	76	73	67	63	57	82	70

SQB-10

RPM	Hz	63	125	250	500	1K	2K	4K	8K	LWA	dB (A)
	1591	66	68	73	65	60	56	53	47	69	57
	1896	67	69	74	71	63	59	57	50	71	59
	2205	73	72	74	75	68	63	62	55	75	63
	2517	77	73	76	78	71	68	68	61	77	65

SQB-12

RPM	Hz	63	125	250	500	1K	2K	4K	8K	LWA	dB (A)
	1105	63	66	68	61	56	55	48	42	63	51
	1508	70	71	74	72	65	64	60	53	73	61
	1885	78	73	76	79	68	68	68	58	78	66
	2255	84	81	82	85	75	72	75	68	85	73

SQB-13

RPM	Hz	63	125	250	500	1K	2K	4K	8K	LWA	dB (A)
	1027	64	66	69	61	58	58	51	43	65	53
	1203	68	67	75	67	60	63	56	49	71	59
	1443	72	75	80	76	68	69	64	56	76	65
	1932	79	82	80	85	75	74	74	67	86	74

SQB-13 HP

RPM	Hz	63	125	250	500	1K	2K	4K	8K	LWA	dB (A)
	1089	68	63	66	63	57	57	53	46	63	51
	1264	70	67	70	68	61	61	58	51	68	56
	1561	73	73	76	73	65	65	63	57	75	63
	1802	75	76	81	77	70	70	69	61	78	66

SQB-15

RPM	Hz	63	125	250	500	1K	2K	4K	8K	LWA	dB (A)
	855	62	64	69	64	58	56	48	40	64	52
	1192	70	71	77	71	67	66	62	55	73	61
	1542	77	74	84	77	70	70	68	65	80	68
	1836	82	78	86	85	76	75	74	70	86	74

SQB-15 HP

RPM	Hz	63	125	250	500	1K	2K	4K	8K	LWA	dB (A)
	851	54	54	58	53	53	53	47	37	57	45
	1197	68	58	65	65	61	60	58	48	67	55
	1918	69	72	78	75	74	73	70	66	81	69
	2378	72	78	82	83	78	78	76	73	87	75

SQB-16

RPM	Hz	63	125	250	500	1K	2K	4K	8K	LWA	dB (A)
	793	63	67	70	66	59	57	48	43	66	54
	1079	69	71	79	74	69	67	57	52	75	63
	1445	76	76	87	83	74	73	67	62	82	70
	1817	83	83	90	88	81	77	74	69	88	76

SQB-16 HP

RPM	Hz	63	125	250	500	1K	2K	4K	8K	LWA	dB (A)
	796	57	60	64	59	56	53	48	39	62	50
	1483	75	75	80	77	72	70	69	62	77	65
	1799	75	77	85	78	76	73	72	68	82	70
	2038	75	80	88	83	79	75	74	71	85	73

SQB-18

RPM	Hz	63	125	250	500	1K	2K	4K	8K	LWA	dB (A)
	871	73	72	76	71	65	63	55	48	71	59
	1132	77	80	83	78	73	71	64	57	80	68
	1398	82	84	87	84	80	77	72	64	84	72
	1612	85	86	92	88	83	83	77	70	89	77

SQB-18 HP

RPM	Hz	63	125	250	500	1K	2K	4K	8K	LWA	dB (A)
	761	62	69	64	63	60	57	48	40	63	51
	1056	69	75	75	72	69	66	61	54	74	62
	1362	77	76	82	75	75	74	69	62	80	68
	1671	84	79	86	81	80	78	76	69	85	73

SQB-20

RPM	Hz	63	125	250	500	1K	2K	4K	8K	LWA	dB (A)
	627	65	72	69	67	64	59	51	43	68	56
	812	71	79	77	72	72	68	60	52	77	65
	1043	77	79	85	79	76	76	68	61	80	68
	1237	82	81	88	84	79	82	78	68	88	76

SQB-20 HP

RPM	Hz	63	125	250	500	1K	2K	4K	8K	LWA	dB (A)
	543	58	62	59	58	55	51	44	35	58	46
	781	64	73	70	68	68	65	57	48	70	58
	989	69	74	79	74	72	72	63	56	78	66
	1201	76	75	83	81	77	84	73	65	87	75

SQB-22

RPM	Hz	63	125	250	500	1K	2K	4K	8K	LWA	dB (A)
	647	70	76	72	68	68	62	54	47	70	58
	834	74	79	79	76	73	72	63	55	78	66
	976	77	83	83	80	76	76	70	60	84	72
	1410	87	87	92	87	85	85	82	75	92	80

SQB-22 HP

RPM	Hz	63	125	250	500	1K	2K	4K	8K	LWA	dB (A)
	591	63	68	65	62	59	56	49	40	65	53
	862	68	77	76	73	72	70	62	53	78	66
	1313	79	80	87	86	82	88	78	68	90	78
	1486	81	85	89	88	85	87	81	74	94	82

SQB-24

RPM	Hz	63	125	250	500	1K	2K	4K	8K	LWA	dB (A)
	580	70	76	70	66	68	65	55	45	70	58
	877	79	81	83	77	74	72	68	58	82	70
	1081	82	86	90	82	79	78	75	65	85	73
	1336	86	89	93	92	86	84	80	74	93	81

SQB-24 HP

RPM	Hz	63	125	250	500	1K	2K	4K	8K	LWA	dB (A)
	535	64	70	65	60	63	56	47	39	65	53
	835	72	78	78	72	72	70	64	56	76	64
	1271	80	86	89	84	78	83	78	72	87	75
	1524	82	90	93	90	84	84	85	78	92	80

Datos obtenidos de acuerdo a la norma AMCA ESTANDAR 301.
(Information obtained according to the AMCA STANDARD 301)

SQD/SQB

Dimensiones generales/Dimensions

SQD

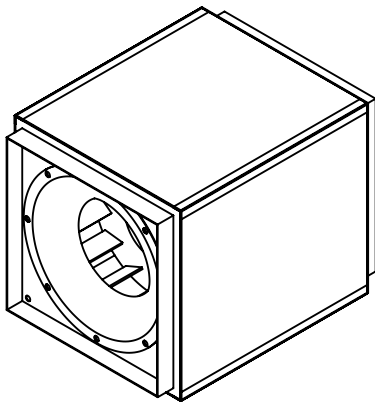
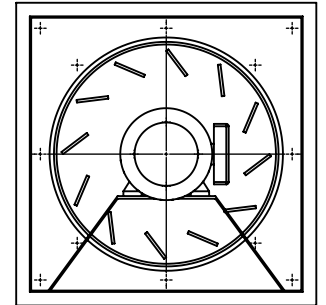
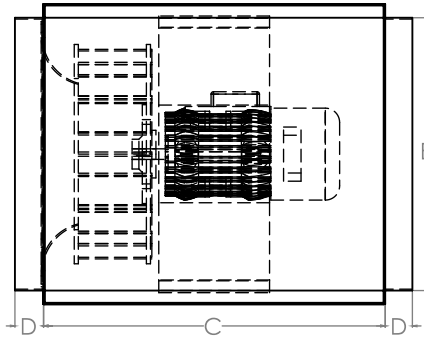
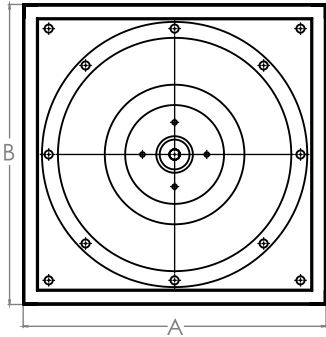

MODELO (MODEL)	PULGADAS (INCHES)				
	A	B	C	D	E
SQD-07	17"	17"	21"	1 1/2"	14"
SQD-10	17"	17"	21"	1 1/2"	14"
SQD-12	19"	19"	21"	1 1/2"	16 1/2"
SQD-13	21"	21"	21"	1 1/2"	18"
SQD-15	23"	23"	23"	1 1/2"	20"
SQD-16	26"	26"	26"	1 1/2"	23"
SQD-18	28"	28"	28"	2"	24"
SQD-20	32"	32"	32"	2"	28"
SQD-22	36"	36"	34"	2"	32"
SQD-24	39"	39"	36"	2"	35"

SQB

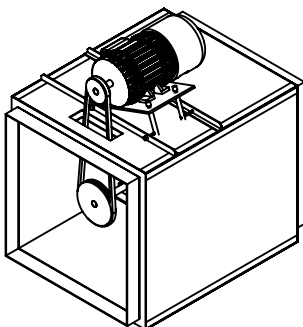
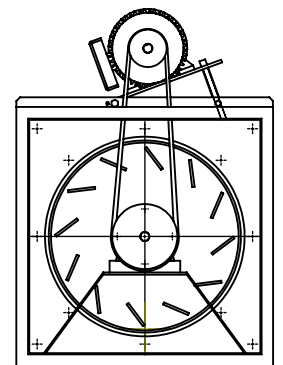
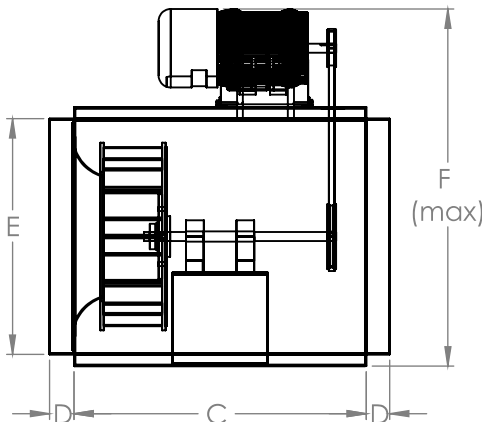
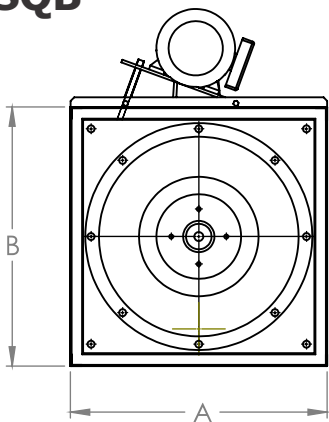

MODELO (MODEL)	PULGADAS (INCHES)					
	A	B	C	D	E	F (max)
SQB-07	17"	17"	21"	1 1/2"	14"	28"
SQB-10	17"	17"	21"	1 1/2"	14"	28"
SQB-12	19"	19"	21"	1 1/2"	16 1/2"	29 1/2"
SQB-13	21"	21"	21"	1 1/2"	18"	32 1/4"
SQB-15	23"	23"	23"	1 1/2"	20"	34 1/2"
SQB-16	26"	26"	26"	1 1/2"	23"	39 3/4"
SQB-18	28"	28"	28"	2"	24"	42 1/2"
SQB-20	32"	32"	32"	2"	28"	46 1/2"
SQB-22	36"	36"	34"	2"	32"	47 1/4"
SQB-24	39"	39"	36"	2"	35"	56 3/4"